

Alexandre Triffault

Co-author : Tristan Guedel

Translated to English by MrAnybody

A Summary of Lockpicking

A better understanding of the practice of non-destructive entry

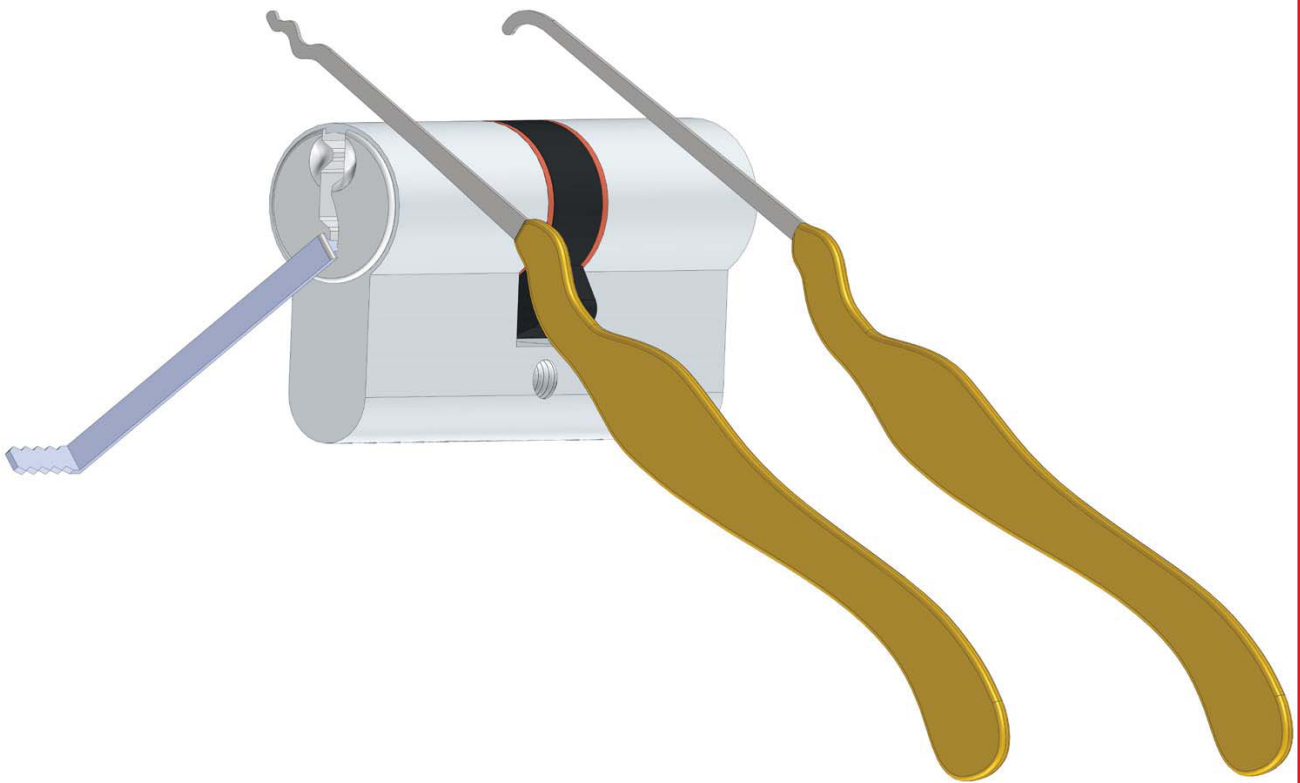

www.intrusion.eu

Table of contents

Warning.....	3
Operation of a standard lock.....	4
The components of a lock cylinder.....	5
The principles of lock-picking.....	9
The anti-picking pins.....	14
The different tools	18
Buying tools	26
Picks for pin tumbler locks.....	29
Making your own tools	35
Picking techniques	38
Conclusion	48

The Code of Intellectual Property prohibits copies or reproductions intended for collective use. In this context, any representation or reproduction in whole or in part by any means whatsoever, without the consent of the author(s), is unlawful and constitutes a forgery, under articles L.335-2 etc of the French Code of Intellectual Property.

Copies or reproductions are strictly reserved for private use only (Article L.122-5 French Code of Intellectual Property)

Warning

According to our approach, the understanding of lock manipulation allows you to highlight the shortcomings of a physical security system, in order to improve it, to protect against the vulnerabilities that exist, while maintaining the professionalism of locksmiths and troubleshooting professionals.

As a result, we make this introduction into the techniques of lock picking available to our customers and locksmiths interested in the techniques of lock opening so the basics can be clearly understood.

For more detailed explanations, as well as an approach to other techniques of fine opening (such as impressioning, and using soft keys, umbrellas picks, bypass techniques, pump/push lock cylinders, disc detainer locks, magnetic locks etc) please refer to our comprehensive book: « Le manuel du serrurier, volume 1, pratique du crochetage et des techniques d'ouverture fine »

(‘The Locksmiths Manual, Volume 1’ ‘The Practice of Lockpicking and Manipulation Techniques’).

Remember that the purchase and use of lockpicking tools is perfectly legal in most countries, providing that they are used only on locks that you own, or with the explicit permission of the lock owner.

In effect, the use of these techniques in a context other than the above would then constitute the criminal offense of breaking and entering, or aggravated burglary as stated under the terms of article 132-73 of the Penal Code by the use of false keys or any other instrument «fraudulently employed to activate a closure system with or without force».

Accordingly, the authors cannot in any way be responsible for any illegal use of the techniques described in this document.

Operation of a standard lock

The most common locks are paracentric pinned locks or flat key locks.

This is not strictly speaking about all locks, since the lock is a generic term which refers to the entire mechanism dedicated to the closure and opening of the door or other mechanism.

Because we are only dealing with methods of non-destructive opening in this presentation, the lock cylinder is what we are interested in, instead of the complete lock or lock case.

However, in order to be more comprehensible and avoid repetitions, we will use interchangeably the terms «cylinder» or «lock» on the understanding that the designation «lock» is actually the «cylinder» and not lock case.

Cylinders are generally available in two distinct forms:

1. **Round cylinders, often mounted on dead bolts,**
2. **European type cylinders, usually fitted with lock case being built inside the door.**

Diagram of two most frequently encountered profiles

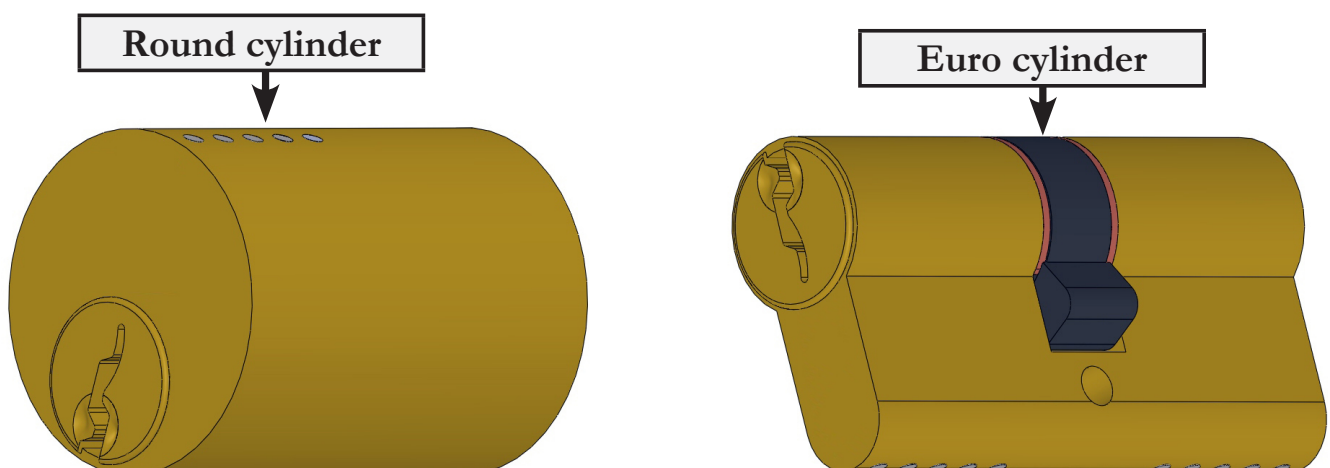

The operation of both the round and European cylinder is identical, and needs to be thoroughly understood before learning to pick them.

Lock cylinder components

In order to master the non destructive techniques to open a lock, let's start with the vocabulary and use of every part of a common lock.

With this new knowledge, we will be able to use a specific technical vocabulary giving us the opportunity to understand how a lock works and how it can be opened without the fitting key.

External view of a cylinder :

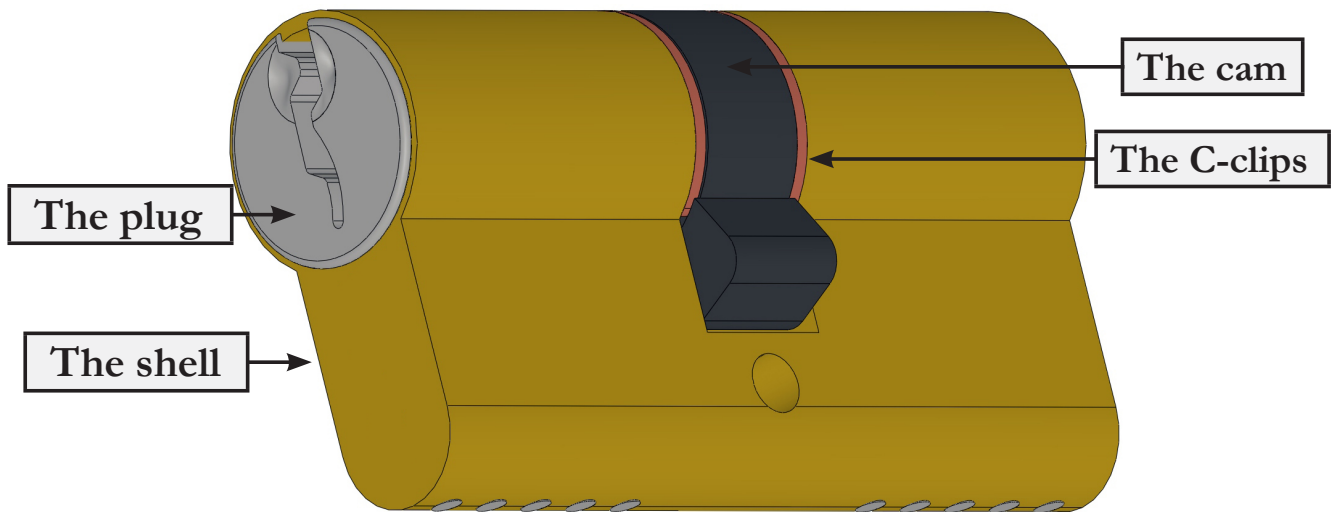

External components of a cylinder :

The shell :

The shell is the motionless part, fitted to the lock case or the door itself.

The plug :

The plug is the rotating part which you insert your key in. It does actuate the cam when you turn the key to lock or unlock

The cam:

The cam is directly connected to the plug and turns with it inside the door or the lock case. It does actuate the door locking mechanism.

The C-clips :

Those are thin C shaped strip of metal surrounding the rear of the plug, preventing it to pop out when a key is inserted.

Sectional view of a European cylinder

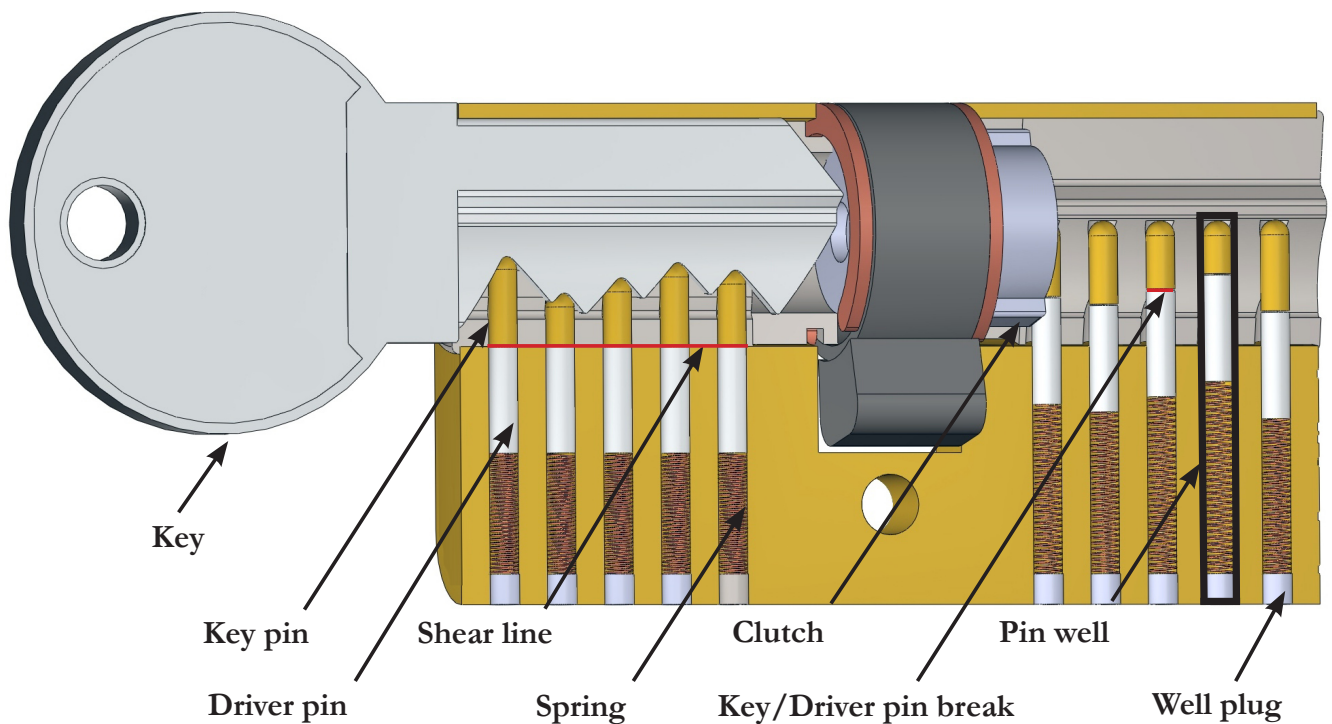

The key pins :

These pins are in contact with the driver pins at their bases and with the key at their tips. They are different lengths, so that only the right combination of key cuts can align them at the shear line and permit the opening of the cylinder.

The tip of a key pin is usually rounded off in order to minimize friction with the key as it's inserted into the keyway.

The driver pins:

These are in direct contact with the springs and key pins, and they pass through the plug and shell.

When there is no key inserted, the pins form an obstacle to the rotation of the plug, and therefore prevent the opening of the cylinder, as shown in the right part of the diagram above.

However, when the correct key is inserted, the driver pins remain positioned inside the lock shell and at an equal height along the shear line. The plug can then rotate to allow the mechanism to open or close. This can be seen on the left side of the diagram above.

The pin wells:

The pin wells pass through the lock plug and shell. They serve to guide the pins and springs, and are theoretically aligned in a straight line that passes through the axis of the plug and shell.

In reality, there are always extremely small variations in the positioning of the pins wells of a few tenths of millimetres or less. We shall later see that these small imperfections are the basis for picking a lock.

The springs:

Forced in the pin chambers, the springs allow the pins to move through the shell and plug. A force is put on the pins when a key or pick is inserted in to the cylinder.

The force of the springs on the pins reads the bitting on the key once it's introduced in to the lock, and also for the pins to return to their initial positions once the key is removed from the cylinder.

The well plugs:

The well plugs are made from brass or steel, and are inserted to seal the ends of the pin wells once the pins and springs have been introduced.

The shear line:

It can also be called «the physical separation of the plug and shell».

The cylinder will open when the breaks between the driver and key pins are aligned with the shear line to provide a space at this line between the lock shell and the plug.

As a result, the plug is able to turn and the lock open while staying attached to the shell by a securing ring to prevent the plug being withdrawn from the shell.

The key/driver pin break :

The key/driver pin break is the physical line of separation between a key pin and a driver pin associated with it.

The Clutch

Located at the rear of the cylinder, inside the cam, the clutch links the plug with the cam on the side of the inserted key.

The components of a cylinder: the essential to keep in mind

The lock cylinder always includes a static component called the 'shell' and a mobile component called the 'plug'.

It is the rotation of the plug that allows the cam to be led, and so to open and close the lock.

1. Example of the rotation of the plug in relation to the cam

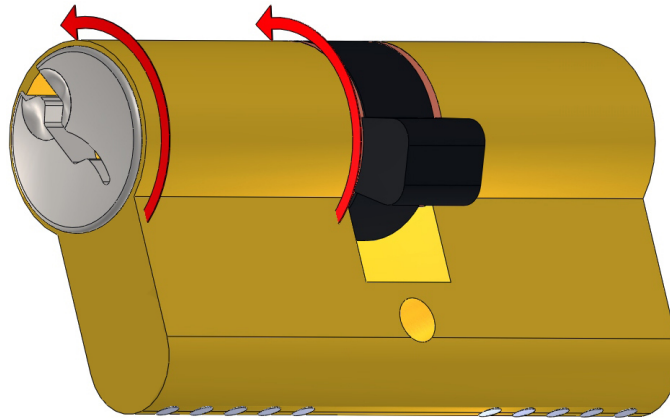

2. Front view of the action of the key on the pins

<p>When no key is inserted, the plug cannot rotate because its rotation is blocked by the driver pins. When the incorrect key is inserted, the plug cannot rotate because its rotation is blocked by either the driver pins or key pins.</p>		<p>When the correct key is inserted, the line of separation between the key and driver pins is aligned with the line of separation between the plug and shell. As a result, the plug is free to rotate.</p>	
--	--	---	--

3. Side view of the action of the key on the pins :

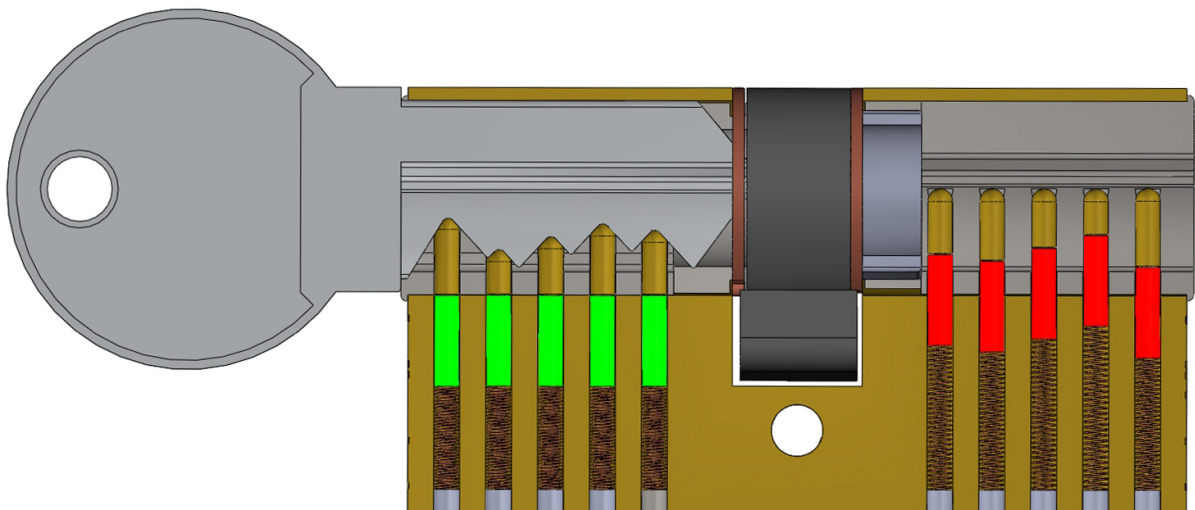

The Principle of lockpicking

If there are areas which do not suffer from the approximation, the locksmith is the perfect example. Any fault, or even the most subtle vulnerability can be exploited, as long as one takes the time to investigate and understand it. In this way, even the effectiveness of a particular system that's theoretically perfect can be negated.

The essence of the lock manipulation is to discover and exploit these vulnerabilities in order to successfully operate the locking mechanism without using destructive methods or using the intended key.

To understand the first of these vulnerabilities, let's imagine a perfect straight line on which a number of holes are aligned. The pin stacks and springs of the cylinder are placed in these wells.

This theoretical line is a common alignment found in all pinned locking devices, as shown in the diagram below.

An outline of the theoretical alignment of pin wells in a shell

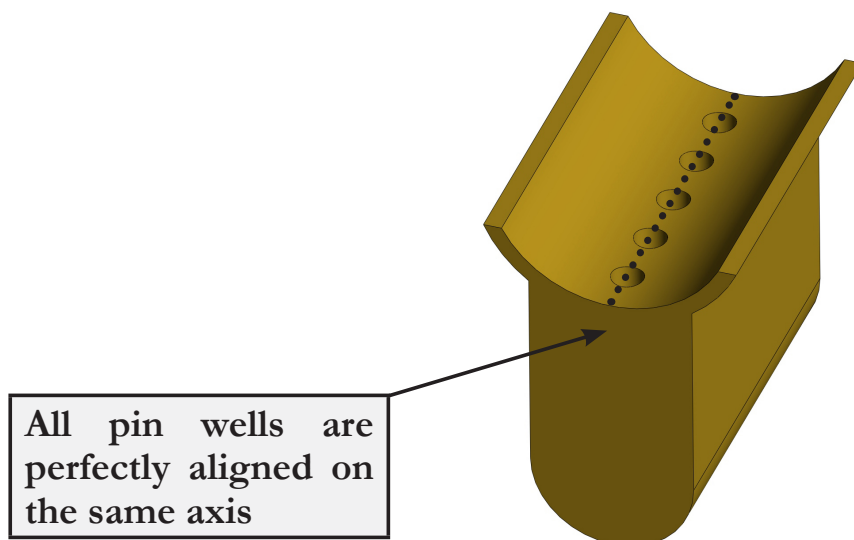

Note: fortunately for the locksmith, the perfect alignment only exists in the field of pure geometry.

In reality, even the most advanced milling machinery are unable to mill or drill a perfect linear line for the pin wells.

Thus, the pin wells are in reality misaligned and even sometimes of different diameters. While these differences are generally not exceeding a few tenths of a millimetre, it is sufficient for the whole principle of lockpicking to function.

In fact, if all the pin wells were aligned in a perfectly straight line (as shown in the last illustration) all the pins would be in simultaneous contact with the plug and shell. As a result, it would be impossible to determine in what order to set the pins when picking the cylinder.

Diagram of a theoretical perfect alignment of the pin wells

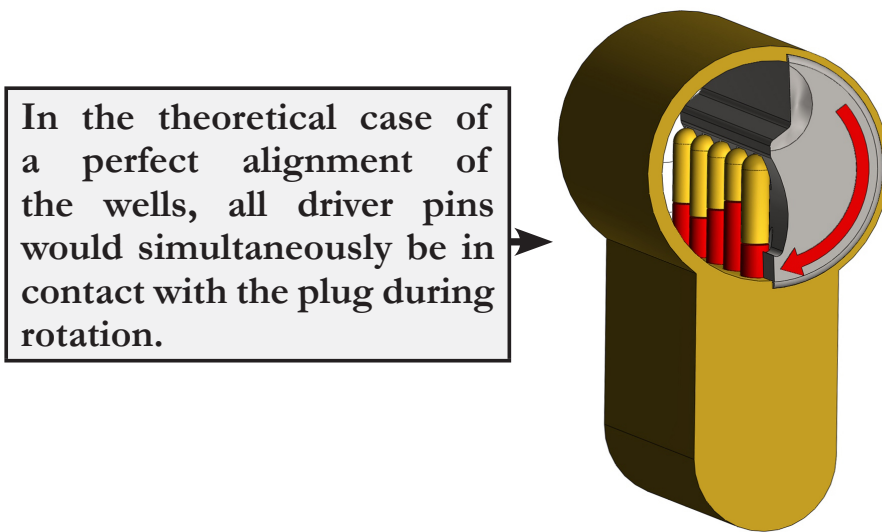

In fact, as we have explained, the orientation of the line where the pins are located is never perfect, and would be closer to the following diagram deliberately exaggerated to illustrate the point.

Illustration of non-alignment of the wells in the shell

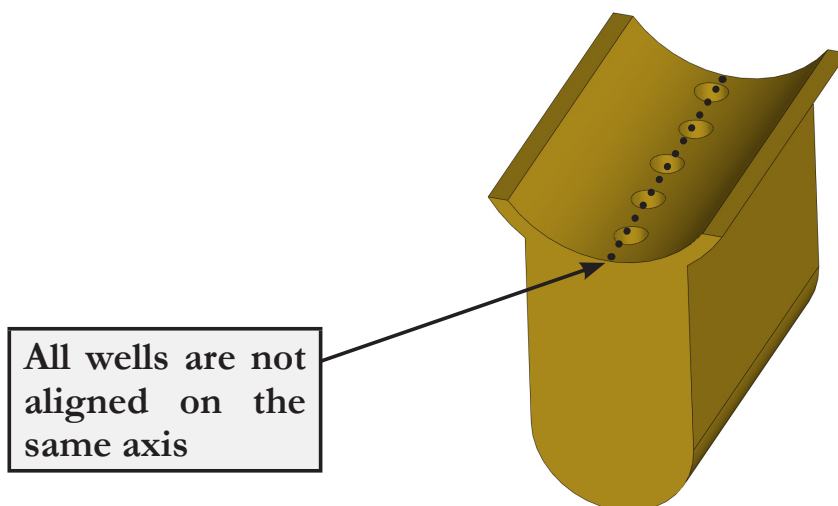

As the pin wells are never perfectly aligned, **when tension is applied on the plug, its rotation in the shell is then blocked by a single pin rather than all of the pins.**

Section of a plug whose wells are not perfectly aligned

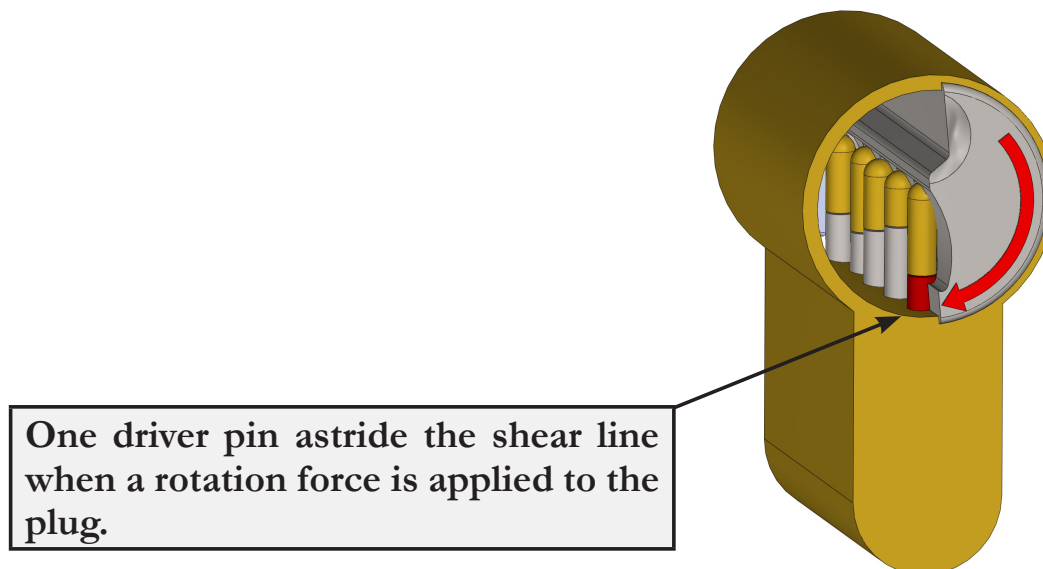

As a result, while the lock is being picked, and tension is applied on the plug (using a suitable tension tool), the friction occurs with a single pin at a time as it is trapped between the shell and the plug.

Other pins may, at this stage, be easily set in place, but they will return to their resting position at anytime because they are not held by the friction of being in contact with the walls of the wells in the plug or shell.

So you will need to acquire the necessary touch in order to understand the pin that is bound by the friction, in order to set it in place with its base at the shear line that separates the plug and the shell.

When a binding pin arrives at the shear line you will feel a clear “snap” or “click” sound, and this pin will not move any further without releasing tension.

Indeed, once the pin placed, it remains there because the plug will have rotated a very small amount and will prevent the pin stack from returning to its position of rest.

View of a pin passing the shear line

Once the pin positioned at the shear line the plug rotates one or two degrees, to bind the next pin with friction. These also prevents the pin returning to its position of rest under the pressure of the spring as it sits on the very edge of the plug well.

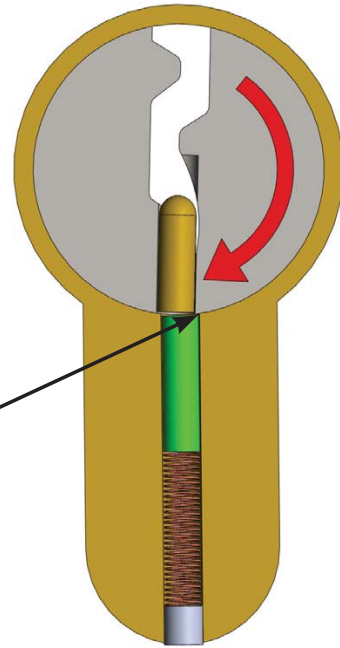

Once the first binding pin is placed at the shear line, it no longer exists as an obstacle between the plug and the shell.

Therefore, the plug, which is under pressure from the tension tool, rotates one or two degrees, until that rotation finds opposition from the next binding pin which will bind on well wall, and block further rotation until it is positioned.

Interior view of a plug on which a rotational force is exerted, the first pin has been brought to the shear line, and a new pin (pin 4) is binding.

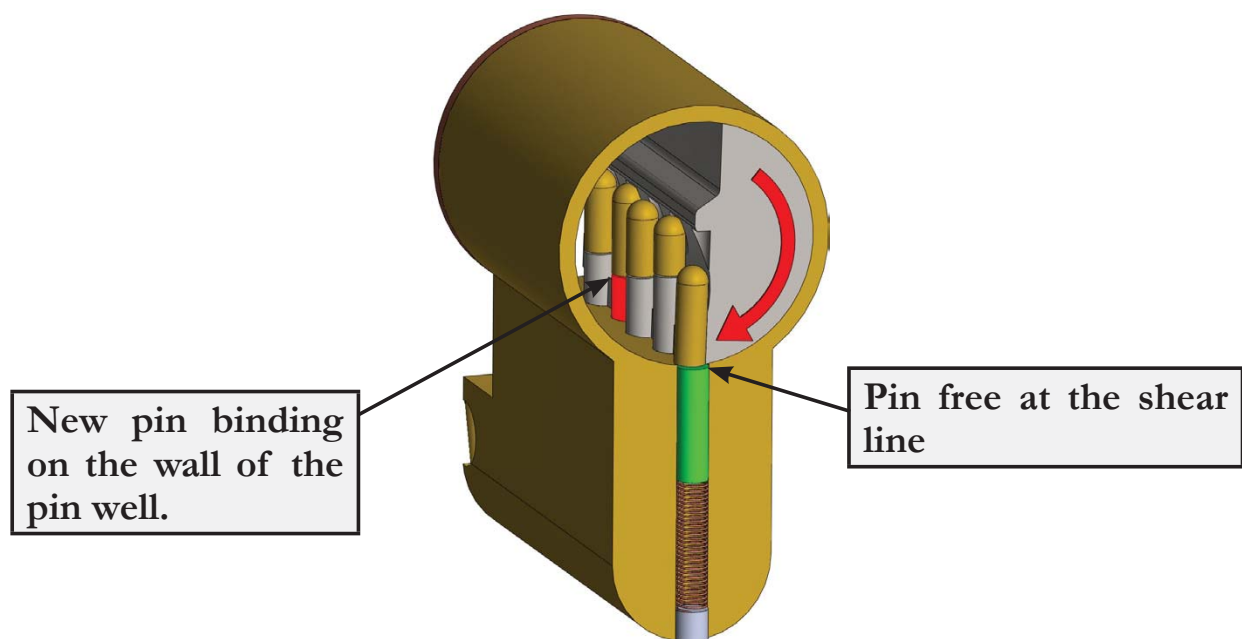

To open the cylinder, repeat the process by setting the binding pins at the shear line until they all are correctly positioned. The cylinder can then be opened as if the original key had been used.

Sectional view of a plug in which all the pins have been brought to the shear line. Full rotation of the plug is now possible

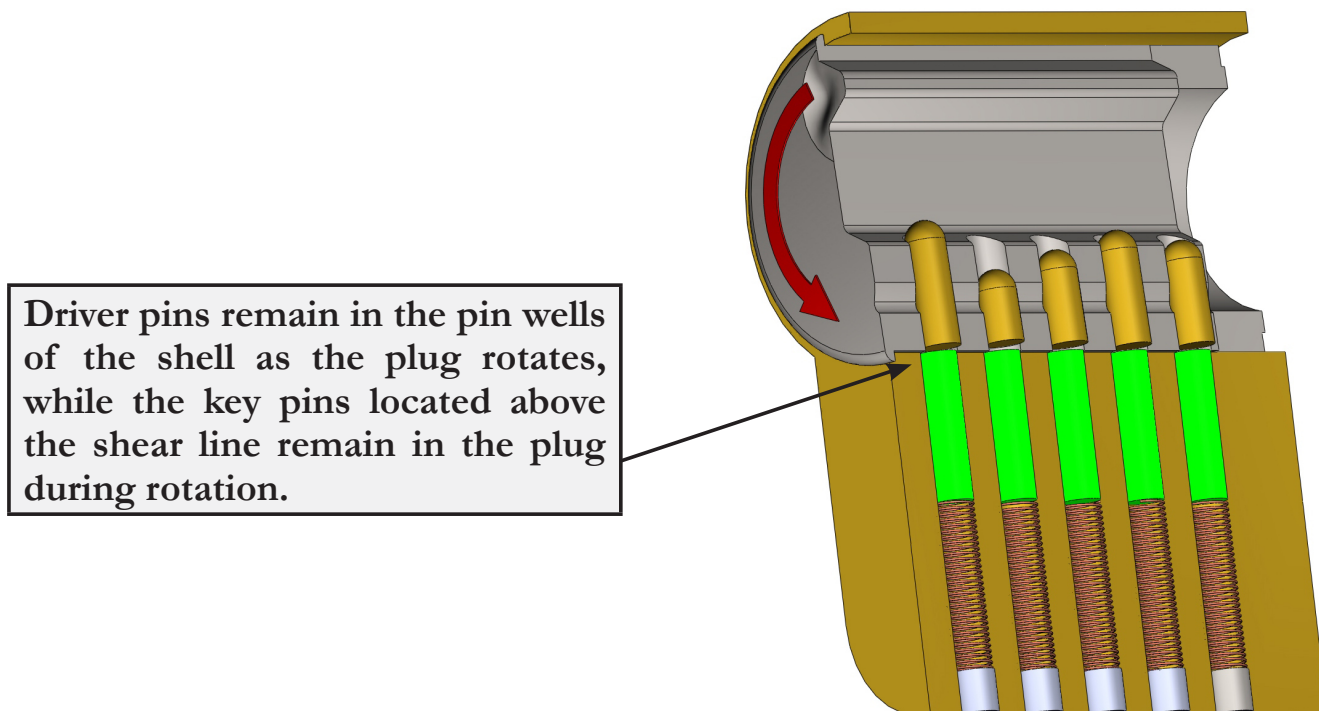

Of course, if the theory seems simple, it does in fact require long hours of practice to understand the feedback of sensations given by machined defects in the order of one tenth or hundredth of a millimetre ...

Furthermore, in many cases, the manufacturing defects are so subtle that several pins come bind at the same time when a turning force is exerted on the plug, and in this case the picking of the lock can be fairly long and delicate because it is difficult to recognise the binding pin.

If you have understood this chapter on the principles for picking locks, we can now examine how lock manufacturers try to defeat a lockpicker.

The Anti-picking Pins

Several methods are used by manufacturers to try to prevent, or at least delay, the manipulation of their cylinders, including trying to distort the feedback perceived during picking, or trying to discourage the insertion of picking tools in the plug with intricate keyways.

1. The difficulty in interpreting feedback

As we have seen, the feedback transmitted to the picker through the tools allows him to know if a pin is set or not.

To prevent the lock being picked, the manufacturers therefore seeks to mislead him.

In order to do this they use “anti-picking pins”, sometimes called “security pins”, for the purpose of implying that a pin is set at the shear line when this is not the case.

These anti-picking pins are generally used as driver pins, but some manufacturers also use anti-picking pins as key pins.

Comparative view of the most common anti-picking pins :

Mushroom pin



Spool pin



Serrated pin



All combinations of number and type of anti-picking pins are possible in a cylinder. It may happen that all driver pins of a cylinder are anti-picking pins of similar or different forms, but it is not uncommon that a cylinder does only have only one or two, while the other pins are of standard type.

One can also note that the spool type pins are most frequent in cylinders, while the serrated and mushroom pins are not as common on European cylinders.

Tension applied to a plug with a mushroom pin

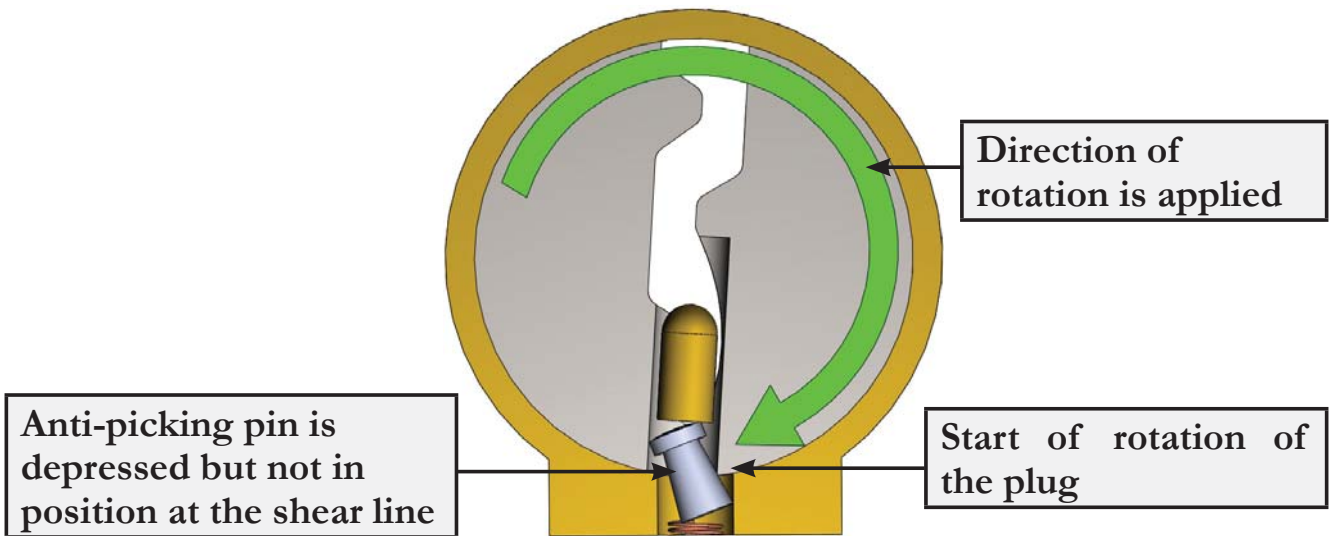

As can be seen, when pressure is applied to one of these anti-picking pins the plug rotates slightly. This rotation gives the impression that the pin is set at the shear line.

However, an essential difference, between this trick and the positioning of the pin on the true shear line is pretty easy to understand: when an anti-picking pin is depressed but not positioned at the shear line, as in the diagram above, you will find that when pressure is then again applied to the pin with a pick, the plug will counter rotate since the play given by the anti-picking groove is then passed.

The function of an anti-picking pin

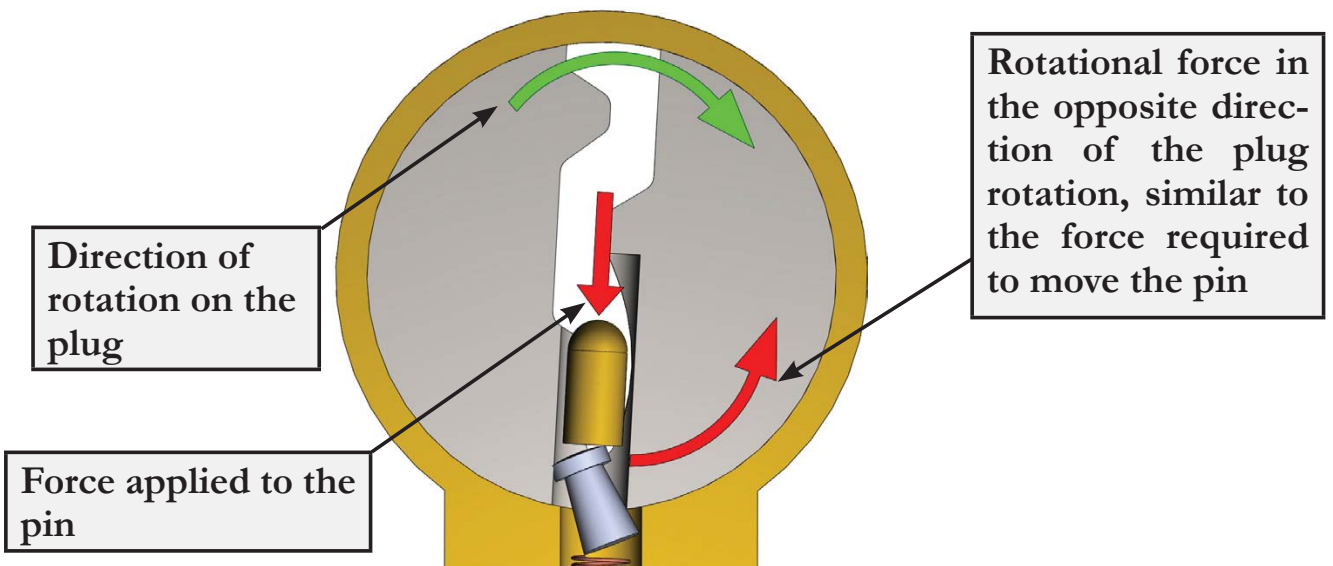

Overcome the anti-picking pins

The method for overcoming anti-picking pins is very simple in theory, but requires some practice to master.

It involves applying a very low pressure on tension tool (just enough to hold it in place), while applying pressure on the binding pin with the tip of the pick.

When you put pressure on the anti-picking pin, you felt the plug rotate a few degrees, but you will find that by stroking your tool again on the pins, the plug will counter-rotate and this anti-picking pin can still be set.

You apply pressure to this pin, and by fluctuating the tension on your tension tool you can allow the plug to counter-rotate until the moment where you will hear and/or feel the slight click of the pin as it's positioned at the shear line. This will also allow the plug to rotate a few degrees in the direction of picking.

You can be sure that it is the shear-line and not an anti-picking bait because if you press again on the pin, it will not be likely to return the rotor backwards anymore, being permanently blocked by overlapping wells of the rotor and stator

Mushroom pin on the shear line can no longer be depressed

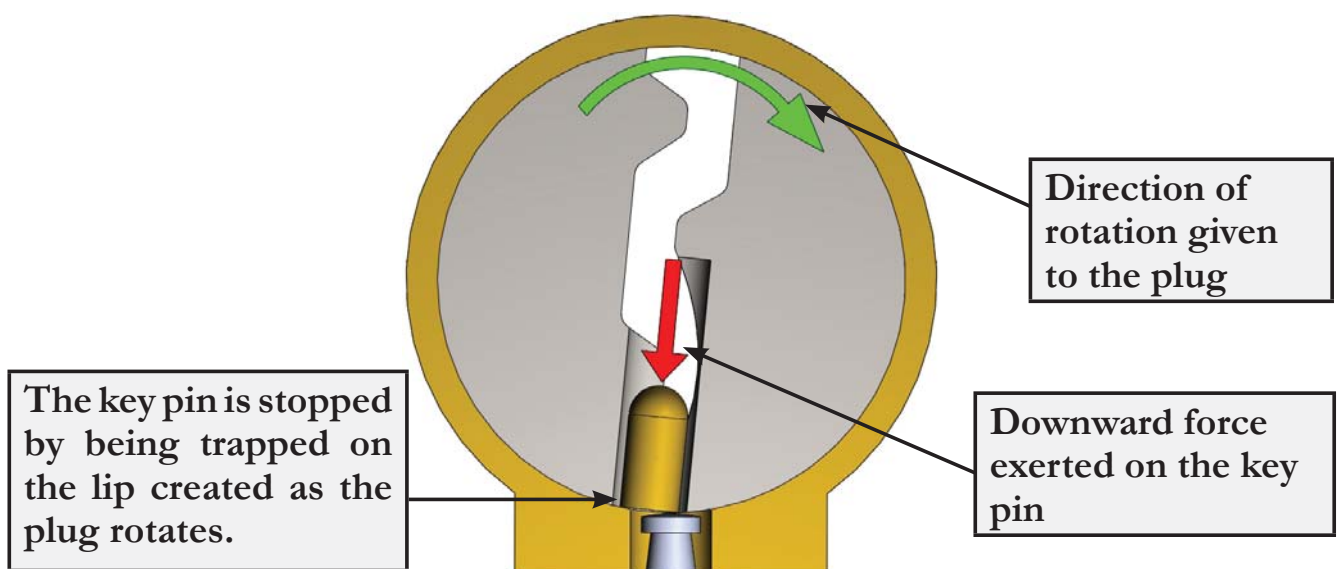

The anti-picking pins are therefore, in general, fairly easy to circumvent on the condition that particular attention is paid to the amount of tension that's applied to the plug with the tension wrench.

If this pressure is higher than the pressure applied to the pins by the pick, the counter-rotation will not be felt, and any progress will be blocked

As with regular pins; if you place one of the anti-picking pins correctly but any pins then unset, it is a sign that the anti-picking should be set before it. Once the binding order (and so, the order of setting) is determined, the opening of the lock should only be a formality.

The different tools

There is a bewildering array of tools a newcomer can buy and try out for his first kit.

However, if this diversity seems to have no limits other than the (sometimes wild) imagination of manufacturers, it is only a small number of these that will prove to be truly useful.

First of all, note that picking always requires the simultaneous use of two distinct tools: a tension tool that has the function of applying rotational force on the plug in order to bind the pins (and ultimately to open the lock) and the pick, which has the function of applying pressure on the key pins in order to set them on the shear line.

The tension tool and pick

Tension tool

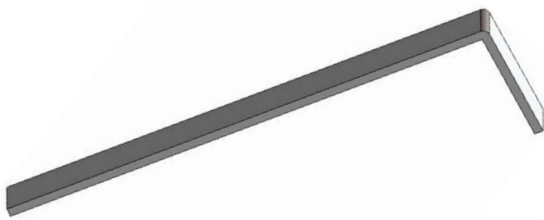

Pick

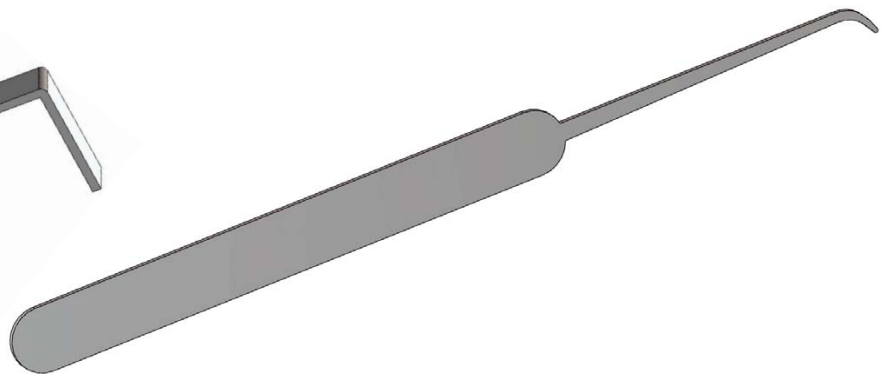

A tension tool and feeler hook in action

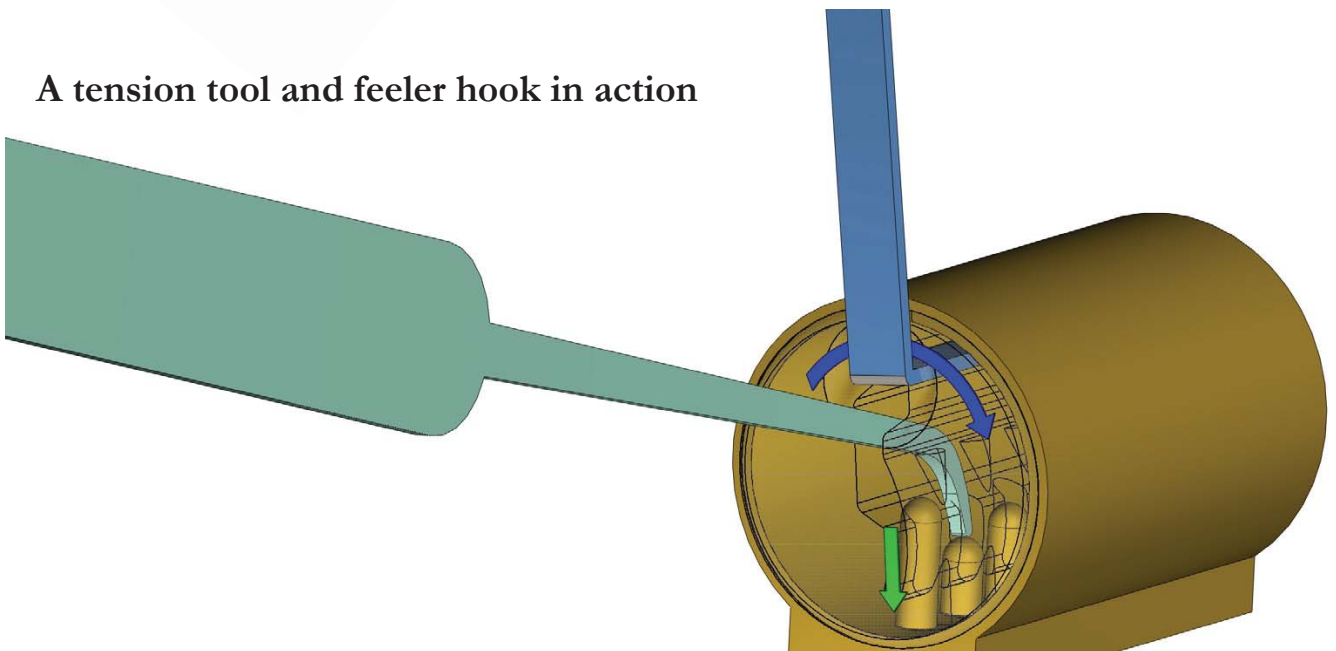

The tension tools

Less attention is often paid to the tension tool than tools such as feeler picks. In addition, manufacturers themselves seem to consider that one or two types of tension tool are sufficient in the pick sets they sell.

This really is a mistake because in most cases it is the choice of tension tool, how it's positioned in the lock and the amount of pressure applied to it that is as important, or even more important, than the pick used to apply pressure on the pins.

As explained above, the role of the tension wrench is to exert a rotational force on the rotor so that the pins are caught in shear between plug and shell and can then be gradually lowered until the shear-line and there remain in position.

Tension tool in action

Driver pins trapped between the plug and shell need to be brought to the shear line to allow the opening of the cylinder.

Once the pin is brought to the shear line it is no longer trapped between the plug and shell.

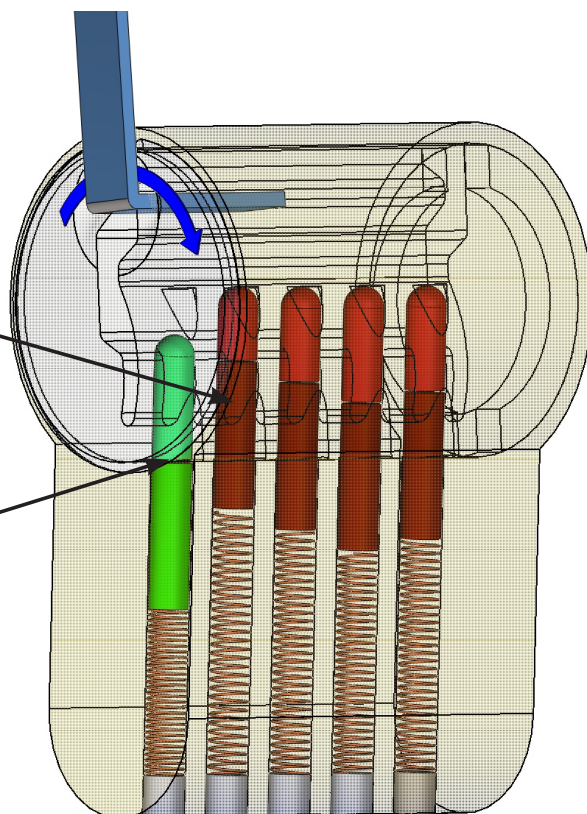

The key element to lock picking is the level of tension applied to the plug by the tension tool. Since it is not sufficient only to apply a constant mechanical strength, but it must be carefully controlled and constantly adjusted according to the feedback the picker interprets.

Too much tension

Applying too much tension will block all the pins. From this it will not be possible to locate the binding pin. There is also a risk that a pick will break as it applies an excessive amount of force to set a key pin.

If you are new to lockpicking, and you're having problems opening your first locks, the problem is usually too much tension applied to the plug.

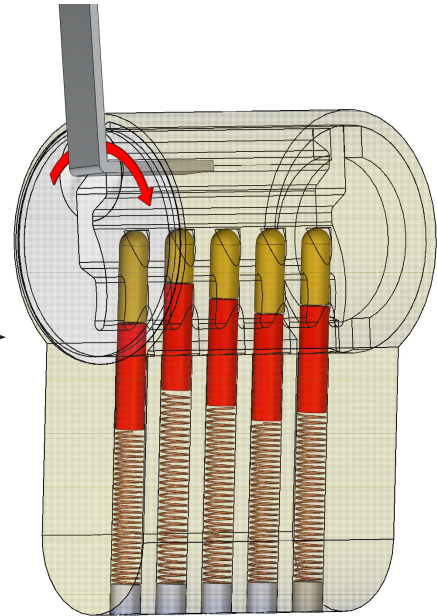

Too little tension

In contrast to the negative effects of too much tension, too little tension will not allow the pins to bind and be set at the shear line between the plug and the shell.

You will not be able to perceive which pin is binding and the pins will not stay in place once they are set.

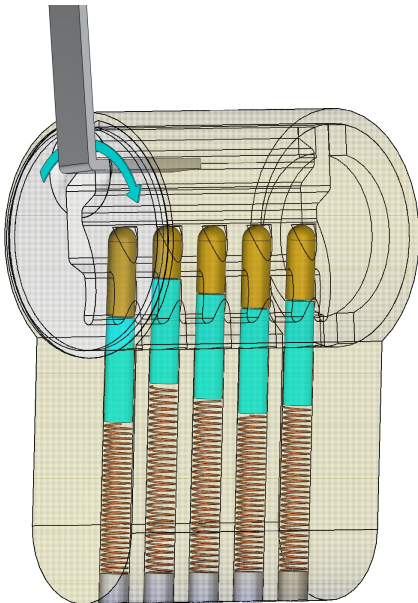

Correct tension

The correct tension to use is one that allows the first binding pin to be held by friction on the walls of the pin well while remaining free enough to be set in position by the pick.

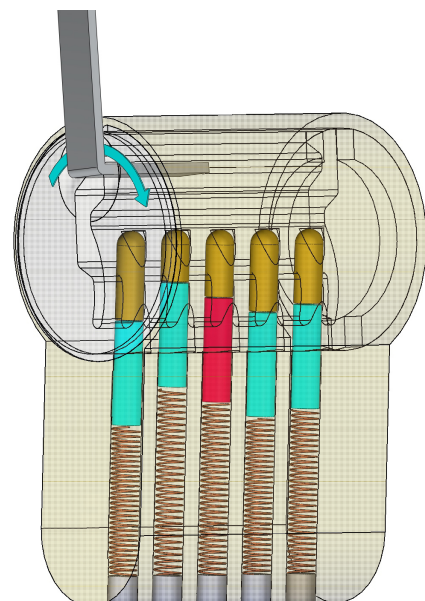

The applied tension should be light, but must be enough to allow a pin to be set in the plug.

When the tension is too strong, the feedback will be lost and the opening of the cylinder will become an unknown.

Of course, there are some cylinders that require more tension, but with a little experience the picker will be able to understand the necessary tension that's needed based on the feedback given by moving the pins with the pick in order to set them.

Correct tension is a tension that gives the picker maximum feedback when picking the cylinder, as in the difference between the following three examples:

1. A pin that is not set and free in its well: by applying pressure on the pin with the tip of the pick the opposing force of the spring can be felt.
2. A pin that is not set, is binding in the plug and needs to be set on the shear line: this pin can be moved with pressure from the tip of the pick, and a small “click” can be heard when it's set at the shear line. This is accompanied by a very slight rotation in the plug.
3. A pin that is correctly set on the shear line and can no longer be depressed: a very light play can be felt, but the pin cannot be moved further without excessive force on the pick.

Use of conventional tension tools

Conventional tension tools consist of a single metal strip bent to a small L-shape. The smaller length of the “L” is inserted into the keyway of the plug, while rotational pressure is exerted on the longer length of the “L”.

To allow enough room for the pick to also be inserted in the keyway, and for the lock to be picked, the tension tool should be securely placed at the bottom or top of the keyway.

Indeed, it is only these two positions that allow enough room for the pick to be inserted in order to set the pins.

The two types of conventional tension tools

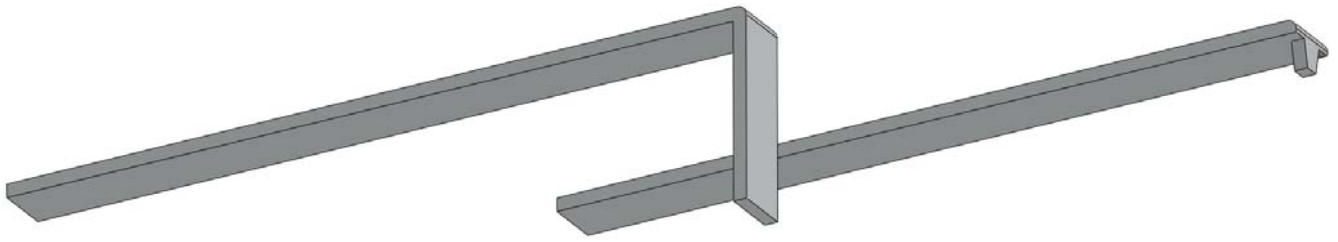

Depending on whether the tension tool is inserted at the top or bottom of the keyway, the smaller length of the “L” will vary in size and thickness to give maximum fit. For top of the keyway (opposite of pins side), a length of about 1cm would be perfect. Additional grip can be given by serrations or small teeth on the end of the tension tool that’s inserted in the keyway.

For bottom of the keyway the length inserted in the keyway should be no more than 1 or 2 millimetres to prevent it coming into contact with the first pin. It will often be thinner than top of the keyway tools so it can be properly inserted.

Views comparing the end of the tension tool for top of the keyway and bottom of the keyway

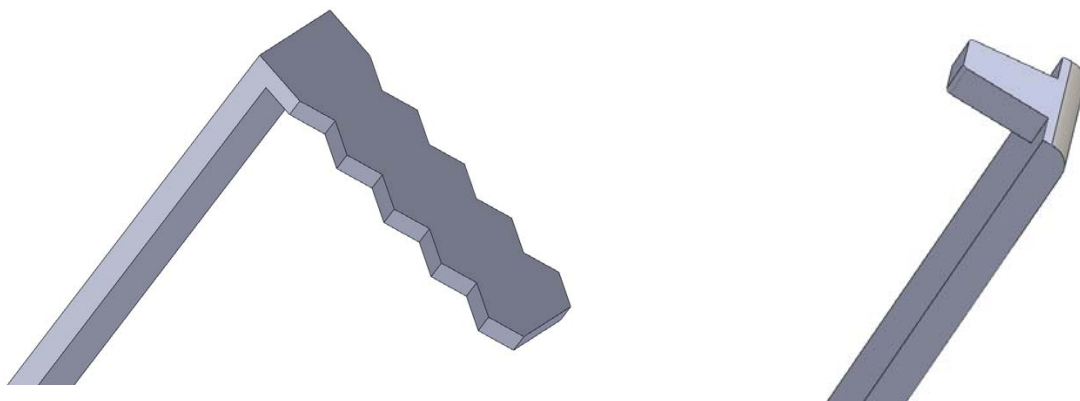

The length of the longer end of the tension tool is not as important, but lengths of around 5cm are advisable to avoid them coming into contact with the door frame or handle when picking a lock.

On the other hand, the tension tool transmits useful information (feedback) to the fingers of the picker, in particular concerning the small changes in rotation of the plug and the movement of security pins that require some counter rotation in certain situations.

As a result, it is better to focus on tension tools of rigid metal as they will give maximum feedback, even if some pickers successfully use more flexible tension tools.

Finally, while it is most common that tension tools are L-shaped, it is also quite possible to reduce the number of tension tools by using Z-shaped tension tools. In this way, a tension tool can have a choice of two ends to insert at the top or at the bottom of the plug keyway.

A double headed tension tool that can be used at the top or at the bottom of the keyway.

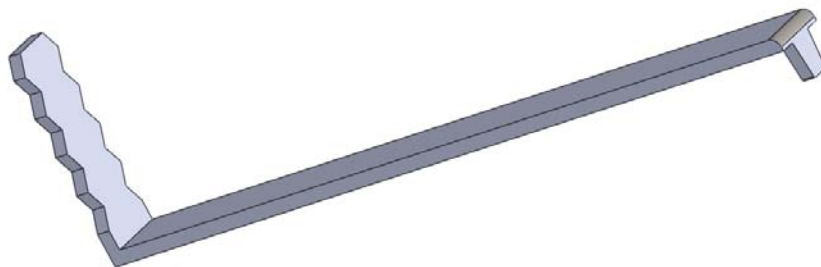

How to tension?

1) Tension from the top of the keyway :

This is the simplest and most conventional position for the tension tool, but this is not always the most effective.

Indeed, to insert the tension tool at the top of the keyway reduces the space available to insert the pick.

However, this technique is still useful to pick relatively simple cylinders.

On the other hand, it also proves very useful for the tension tool to be inserted at the top of the keyway when trying to open the cylinder by raking pins as it can also serve as a guide for the rake.

Illustration of the two options for tensioning at the top of the keyway

Top of the keyway for conventional picking

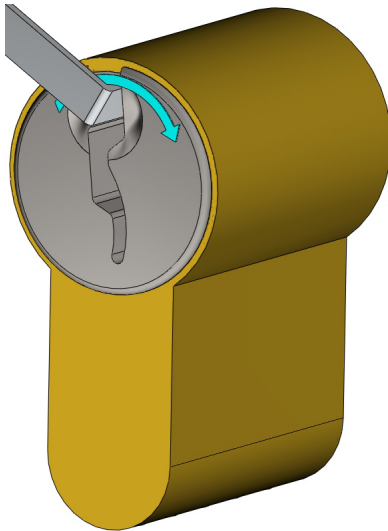

Middle position for a guide in raking

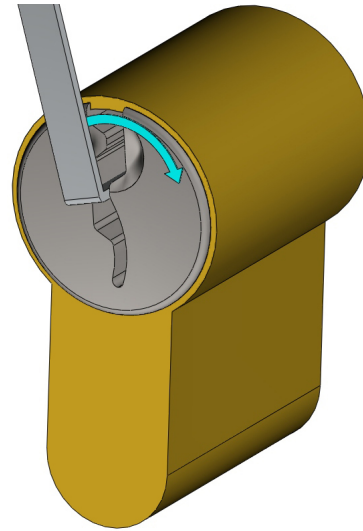

2) Tension from the bottom of the keyway :

It is probably the most effective way to tension a cylinder, especially when it is too complex to be opened by simply raking the pins.

In this configuration, the tension tool is placed at the bottom of the keyway and inserted so the end of the tension tool does not come into contact with the first pin, and result in blocking it when it needs to be picked.

Inserting the tension tool at the bottom of the keyway

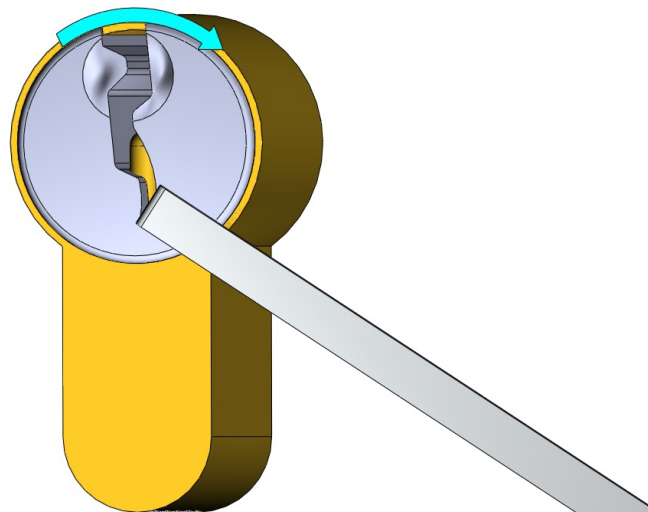

The advantage of this technique is that it leaves the majority of the keyway clear to insert a pick. However, it requires a broader selection of tension tools than top of the keyway, because the best tool to use is dependant on the depth of the first pin in the keyway and the width of the keyway. As a result, it is better to have broader selection of tension tools to deal with most of the typical keyways.

Despite this slight drawback, we strongly recommend that you begin practicing by using bottom of the keyway tensioning.

Indeed, the majority of lockpickers begin with top of the keyway tensioning, but when they come across more complex cylinder locks they will need to change their habits.

Better to make the effort to start directly with bottom tensioning, so it's unnecessary to relearn.

Making conventional tension tools

One or more tension tools are usually provided in most picking kits sold through retailers, but they are not always well suited to narrow locks because they are too thick.

However, it is possible to make them very cheaply from windshield wiper inserts.

Within the rubber blade of a used windshield wiper blade there is a metal blade about 50cm long with excellent rigidity and perfectly adaptable for narrow keyways. By cutting into length of 6 to 7cm you will have an excellent tension tool that is very comparable with those sold by most manufacturers.

If you want to use those tension tools with bottom of the keyway tensioning, 1 to 2mm can be bent at the end, and it can be filed if necessary to fit the keyway.

Finally, these tension tools can be greatly improved by using a small triangular file to cut serrations or teeth into the end sides, so it fits securely in the keyway.

The picks for pin tumbler locks

After initially studying tension tools, now let's look at the picks.

Picking kits found at retailers often include a wide variety of pick forms

While this diversity can sometimes be confusing, it is actually quite easy to navigate.

To do this, we can first divide the tools into tools dedicating to raking and those dedicated to single pin picking :

1. Tools for raking

Raking tools allow the user to quickly open a cylinder without anti-picking pins. The heads of these tools must be able to act simultaneously on multiple pins.

Among raking tools, two sub-categories can be found :

- The tools with teeth, called rakes, five-mountains or city rakes.
- The tools which include a specific curves that act on the pins, called snake rakes because of their snake-like forms.

Snake rakes and city rakes

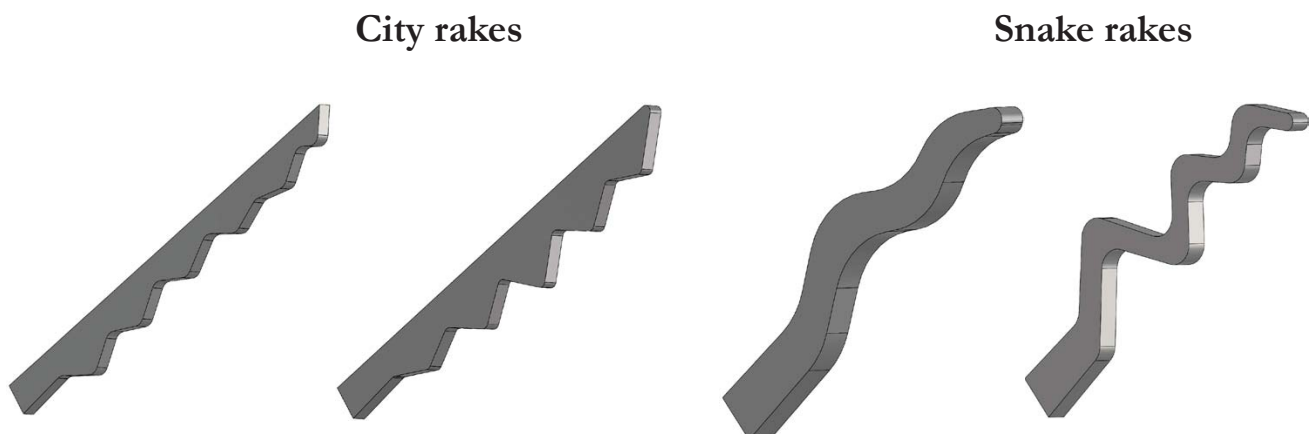

2. The tools for single pin picking

These are the most popular tools designed to act only on one pin at a time, in order to feel the feedback given by every individual pin.

Unlike raking tools, they help to overcome anti-picking pins, and are absolutely essential for opening good quality cylinders.

There are three main types of these tools:

The first category is curved hook picks, also called feelers.

Feeler or Hook pick



The feeler hook-picks are the most widespread and well known tools, as well as the most effective tools for probing. There are many varieties of feelers, with curves more or less pronounced, but choosing a tool with an average curve will allow you to deal with most kinds of situations.

The second category of tools is called half-diamonds, and have the same purpose as feeler hooks to probe the lock pins.

Half-diamond picks



The third category includes tools called half-moons. These tools are predominantly used in wafer locks that, for the sake of economy, have metal wafers instead of pins in the cylinder.

The rounded shape of the tool tip prevents it from getting caught on the wafer as it passes from one to the next.

Wafer locks are generally used on low security locks such as mailboxes or even some vehicles. These types of locks can also be successfully opened by raking or with almost any hook picks.

Half-moon pick



All of the tools described above are available in different forms, with the exception of the feelers that have variations in the curvature.

You will find many kits including two sided picking tools with the characteristics as listed above. In this case it's possible to simultaneously pick two rows of pins on a lock with 2 pin or wafer rows, if the tension tool can be fitted to give enough room to pick this way.

A final category of tools can be mentioned for completeness. These are broken key extractors. These are not strictly speaking picking tools, but with their barbed tips they can be used to snag and pull out a foreign body or broken key from a cylinder.

Key extractors

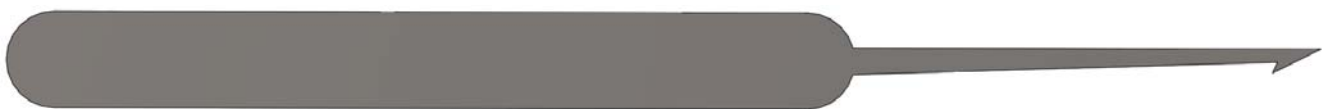

Dimple lock tools

The dimple locks are pin tumbler cylinders with a horizontal keyway. These are unlike conventional paracentric cylinders that have a vertical keyway.

Comparison of a conventional keyway and a dimple keyway

Keyway of a conventional cylinder

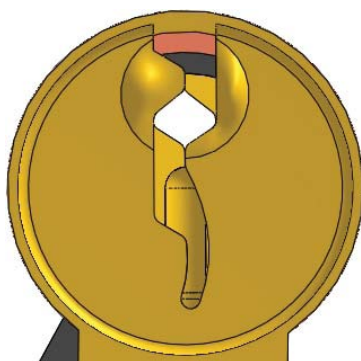

Keyway of a dimple cylinder

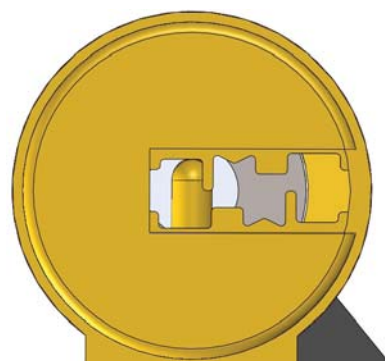

Even if the shape of keys for dimple cylinders is different from conventional flat key cylinders the operation of the lock is the same.

In effect, a dimple cylinder is a simple cylinder with pins, which slightly improves the ability of inserting tools, but generally includes more pins than a conventional cylinder.

Cutaway view showing the function of a dimple cylinder

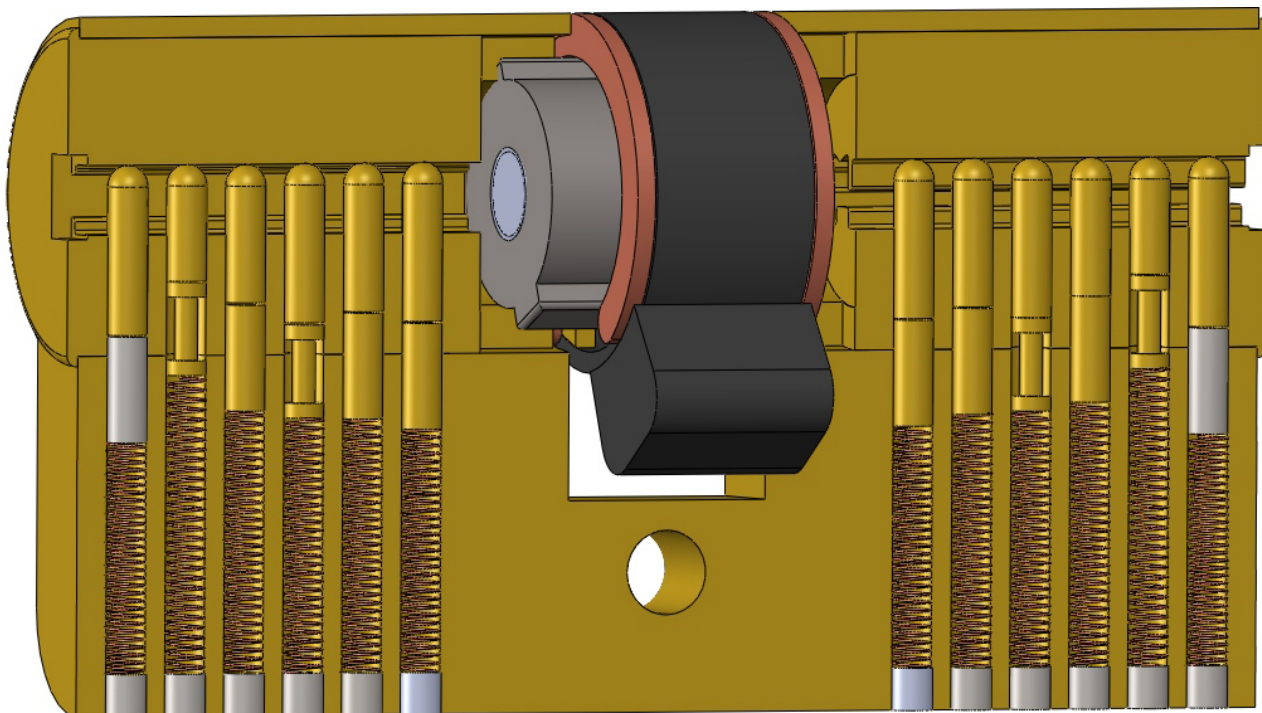

As seen on the diagram above, a dimple cylinder has an identical operation to that of a conventional cylinder, and is vulnerable to the same picking techniques and tools, such as the hook pick and tension tool.

However, it is true that cylinder of this type often include mobile elements in the key, side bar mechanisms or other devices designed to slow down the picking process or lock destruction.

Good quality conventional paracentric cylinders can also have these security designs included in them. Just because a cylinder is a dimple cylinder does not mean it is more secure from picking than a conventional paracentric cylinder.

(Note: To illustrate this point on the diagram above, the plug includes a steel anti-drill pin, and two spool anti-picking pins.)

Use of dimple lock tools

While the tension tools for dimple and conventional paracentric locks are identical, the picks are different because the width of the keyway is not sufficient for a conventional tool.

The tip of the picking tool is offset to the right or the left in order to come into contact with pins by rotating the tool handle.

As a result the pins are not set with a vertical motion, but with a rotary motion of the picking tool.

Using a feeler pick for dimple locks

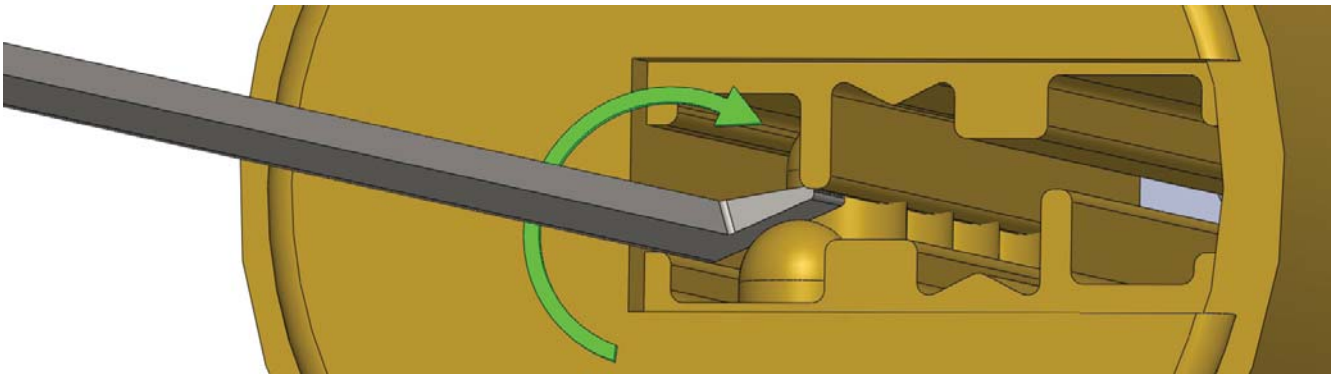

In some cases, a pick originally intended for paracentric keyways with a slightly curved tip will complement with picking of a dimple lock. This can be useful on some common European models on which relatively strong pressure is necessary to set the last pin. This is easier to apply than a rotatory motion.

Some tool tips for picking dimple locks

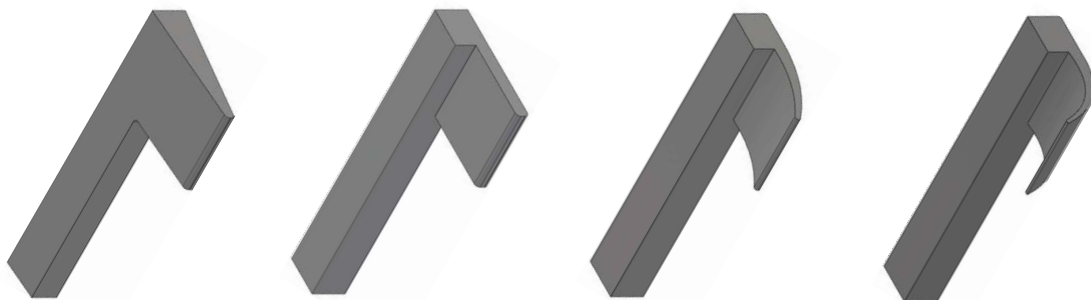

The first tip is generally the most useful, but others may be better suited to specific profiles.

Raking dimple locks

Dimple lock tools intended for raking are, in the majority of cases, made of a simple straight blade, with multiple bumps or dips. This is then inserted in the keyway and moved along the pins to set them.

Unlike picking conventional paracentric locks, it is relatively rare to open dimple locks using a raking technique only as these cylinders generally include anti-picking pins. This makes it difficult to open without using a single pin picking technique.

In addition, as for paracentric keyways, starting with raking the pins often allows some of the pins to set quickly. As a result, valuable time can be gained in opening the cylinder.

Once that is done, you can then set the remaining pins individually.

Some tool tips for raking dimple locks :

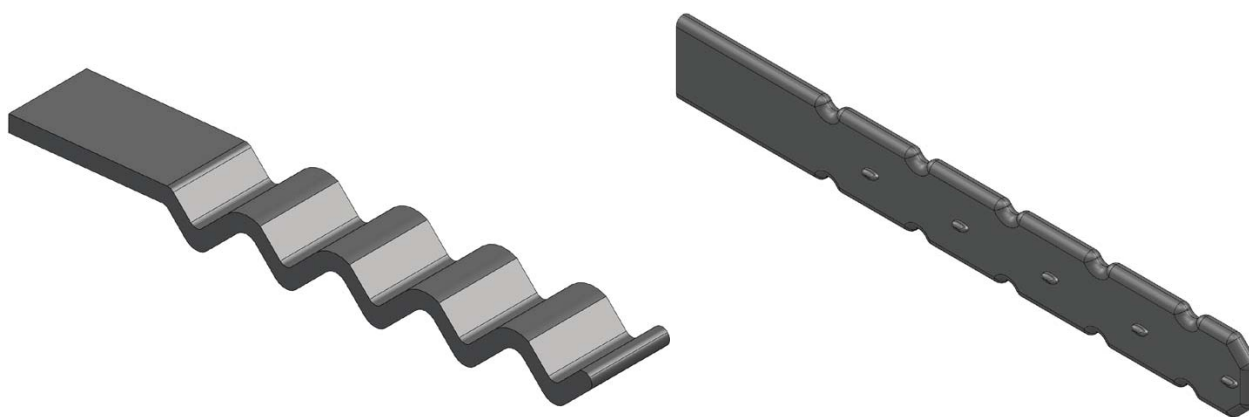

Conclusion on the choice of tools to use :

While there is a wide variety of tools, only one or two of them will be truly useful.

If you have just purchased your first tools, don't expect anything from some of the more eccentric profiles or tortuous looking tools, and keep to the conventional tools that have proven themselves.

As a general rule, a raking tool and an average feeler hook will be sufficient to open any lock providing the user has some practice.

Bought tools

If, as we shall see later, you can easily make your own tools, it is often easier to buy directly, especially as their cost is not excessive. The quality and materials used often add great value compared to handmade tools.

To choose your picks, there are three elements to be considered: the fineness of the tool, its strength and its ergonomics.

1. The fineness of the tool

The fineness of the tool means both the thickness of the steel used, and the height of the pick blade.

The thickness of the steel should in no case be greater than 0.7/0.8 mm. Thicker tools will become difficult to man over in or even enter into the keyway. As a result, the feedback will be much more difficult to interpret.

The thinnest tools currently on the market are between 0.3 and 0.4 mm thick. While these may be the best, they also offer the least amount of strength.

The importance of blade thickness

A thin tool can be inserted in all keyway profiles and avoids having too much friction between the plug and the tool



When purchasing tools pay attention to the height of the blades.

In fact, a significant proportion of tools are designed for the U.S. market. These are very suitable for US locks, and are widely used across the Atlantic as wider and higher keyways are more prevalent there than in Europe. As a result, these tools are often inadequate for European locks and can quickly disappoint their users.

Therefore, it is much more preferable to have tools that are designed for European locks. The blade height should not be more than 3 mm, and should, if possible, be even finer for greater manoeuvrability in the cylinder keyway. Because they are thinner, they can also be used in US locks with no problem.

The importance of blade height

Pick adapted to the U.S. market

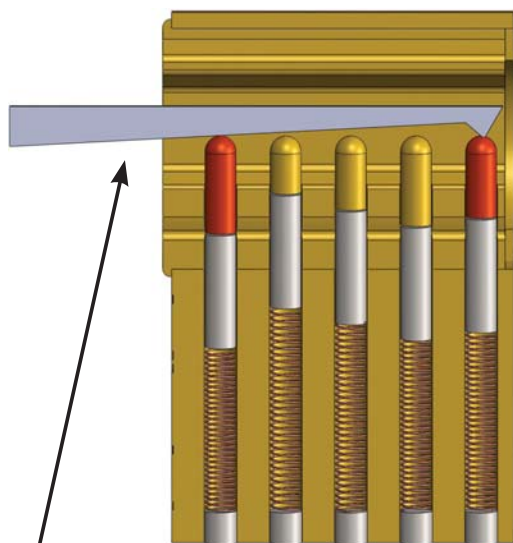

The height of the blade makes it difficult to use the tool. As the 5th pin is picked the blade comes into contact with the 1st pin.

Pick adapted for the European market

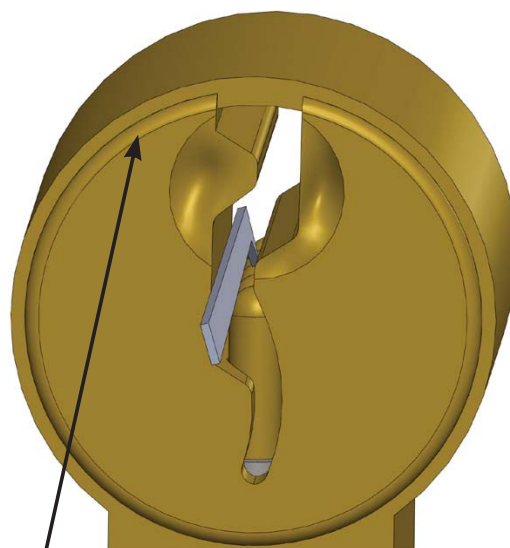

The low height of the blade allows manipulation of the last pin without interacting with the 1st pin.

2. The strength of the tool

Of course, this point is difficult to assess when purchasing.

Without trying to convince you, if possible choose tools sold by European or American manufacturers, or when you are aware of the specifics of the steel used in manufacture. These will generally prove to be of better quality than tools from Asian manufacturers.

3. The ergonomics of the tool

Beyond the only visual aspect, the ergonomics of the tool's handle is not without importance.

In fact, the ergonomics determines the grip and feel when picking.

As a result, relatively wide handles or handles with soft plastic or rubber are not recommended.

They have a tendency to suppress the feedback, which proves counter-productive for picking the lock. The effectiveness of lock manipulation is, beyond the technic itself, very reliant on the feedback given by the tool on the pins.

In contrast, metal or hard plastic handles, with or without the heat shrink tubing are ideal to get a good feel for the opening. However, a thin bare metal handle can tire fingers and become painful to hold during extended picking sessions.

Making your own tools

It is not really necessary to make your own tools since there is such a wide variety of good quality of tools on the market. However, it is very satisfying to open locks with tools that you have made yourself.

Here's what you'll need :

- A small bench grinder
- Glue and paper
- A glass of water
- An iron
- Protective goggles
- Hacksaw blades, or a masonry trowel

The most classic material to use for home-made picks is metal saw blades. They are made of a very good durable and rigid steel, and a thickness of 0.6 mm to 0.8 mm. Even if this is a little thick, it's adequate.

The ideal remains however to use the metal plate of a masonry trowel, which is a technique used by renown pickers, whose tools often of better quality than trade.

This steel is in fact perfectly suited to creating picks, both from the point of view of rigidity, strength and thickness.

You can also use the strapping used to close pallets, or feeler gauges to measure the clearance of the spark plugs (between 0.4 and 0.6 mm)

Once you have the steel for your picks, you need to print a template taken from the internet, and take care of the scale it's printed.

Once the template is printed to scale, you must cut and paste it on to the metal.

A perfect tip for the pasting is to cut a rectangle of paper around the printed pick template you want to transfer, and then soak the rectangle in water for around 5 minutes. Then apply it to the blade being sure that the printed side is on the blade.

Then, skip a very hot iron over the paper so that the ink is deposited on the metal blade. You'll now have a genuine printed transfer.

Once this transfer is made, you can gradually crop the metal using the bench grinder. Take care to plunge the blade in cold water at regular intervals to cool in and prevent the metal becoming brittle.

If a bench grinder is unavailable, a simple metal file can be sufficient even though it requires a lot more time and patience. Once the shape of the tool is finished, de-burr the edges using a file or sandpaper so the pick does not catch on the interior of the lock keyway.

Finally, you can make a handle for a more comfortable grip from heat-shrink tubing (available in electrical and hobby shops). This only needs to be heated for a few minutes in a hot oven or with a heat gun so that it forms perfectly around the blade of the pick.

Another solution would be to cut sleeves from wood, plastic or metal and glue, rivet or weld them to the pick to give a thickened handle.

Steps to make homemade picks

Step 1: choosing the material

Here is a hacksaw blade whose teeth were filed down (for good grip).

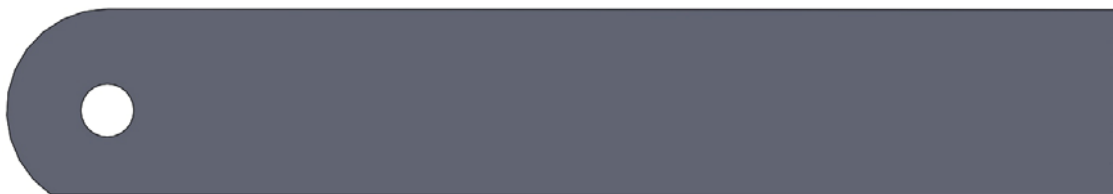

Step 2: Paste the printed template on to the blade

After having soaked the paper template is placed on the blade.



Step 3: Transfer of template print

Once the paper template has been heated by an iron it is removed from the blade. The printed ink remains on the blade.



Step 4: trimming the tool

The tool is gradually trimmed, then deburred with a file and polished.

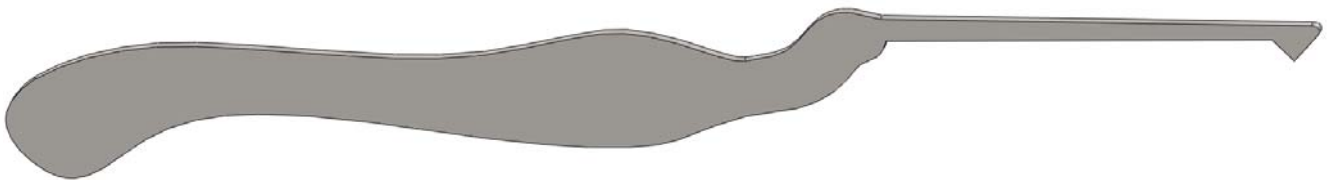

Step 5: Creating the handle

The heat shrink tube is fixed on the handle.

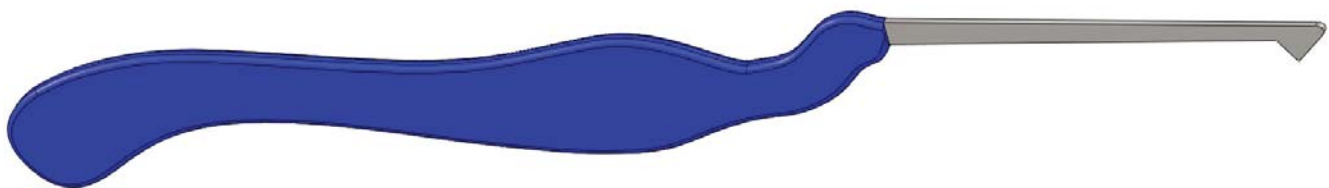

Lock picking techniques

After having understood the operation of a lock pins, let's turn to practicing the technique.

To open your first lock, first start by a low priced cylinder from a DIY store chain (if you buy more than one, be sure to have ones keyed differently, so you train on different key combinations)

These types of locks generally have no anti-picking pins and the machined errors are large. This allows for a readily pickable lock.

It is necessary to not begin your practice with more complex cylinders because, except for a few European models, you will be finding locks with anti-picking pins and complicated keyways.

As a result, you will struggle to make progress and understand the feedback the lock is giving you. These more complex locks will be very useful once you have mastered the opening of low price cylinders.

Similarly, do not start on the cylinders that are already in use or mounted in doors or gates. Indeed, these situations reserved for relatively experienced pickers because of the possibility of breaking a tool in the lock or failing to return the lock to its closed position once it's been opened. This is a reoccurring problem in learning the art of lock manipulation.

1. The raking technique

The technique of raking involves simultaneously setting several cylinder pins at the shear line without having to individually probe each pin in the cylinder.

The pins are progressively set by the action of the rake, and it proves especially in two cases :

- a. When the cylinder does not include anti-picking pins, and so the raking action theoretically allows all the pins to be set at the shear line.
- b. When the pin biting is relatively flat (difference in key pin size is minimal). We will see that locks that have keys pins with a greater variant of height are difficult to rake open.

The combination of these two scenarios is of course ideal for raking, and it is not rare (probably 15-20% of conventional paracentric cylinders) where the lock can be raked in less than a minute, even for a person who is a novice.

2. Using raking tools

As explained earlier in the description of tools, two types of raking tools are common :

- a. City rakes that have cuts at different heights in order to set pins of differing heights.
- b. Snake rakes that work on the same principle as above, but with curves of different heights instead of steep angles.

In fact, the efficiency of both tools is quite similar and use cases are identical. However, we prefer snake rakes because their rounded form glides inside the cylinder while city rakes are more abrasive on the pins.

This can be shown by systematically raking for a few minutes and then tapping the lock face on a flat surface to remove any brass dust.

However, despite this author's preference, you can effectively use either type of tool without fear of damaging your cylinder.

The purpose of raking tools is to simultaneously operate several pins.

As a result, it is easily understood that, unlike the probe, the action on the pins must be relatively uniform, and powered by moving the tool back and forth on the pins.

However, depending on the combination of pin heights, the existing differential between the lowest set pin at the shear line and the highest set pin at the shear line combination is often greater than the difference between the highest point on the rake in contact with the pins and the lowest.

Thus, it is preferable to start with the rake on a parallel line with the pins, and if the lock is not open after some time of moving the rake over the pins back and forth you will need to try different angles with the rake in relation to the pins.

The difficulty in using the raking technique on pin combinations with significant variations

The height difference between the highest pin and the lowest pin here is 3 mm.

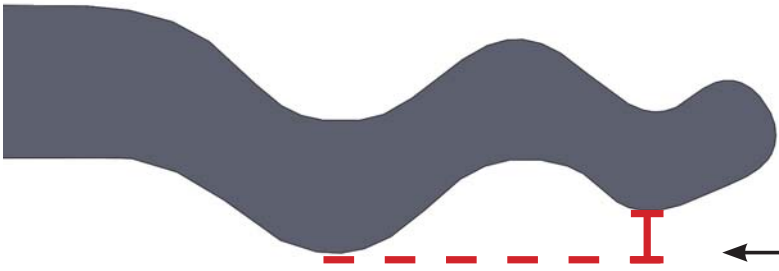
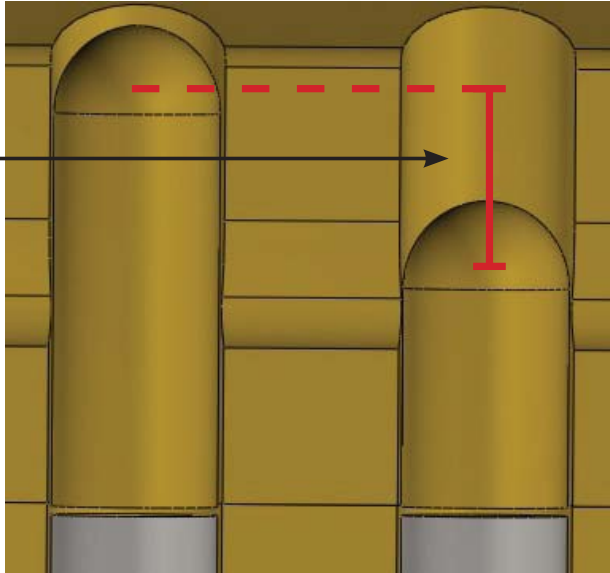

The height difference between the highest and the lowest curve on this raking tool is 1 mm.

Even by positioning the rake at a maximum angle will not be able to compensate for the existing height difference between the highest and lowest pin. In this situation you are unable to set the second pin without oversetting the first or third pin.

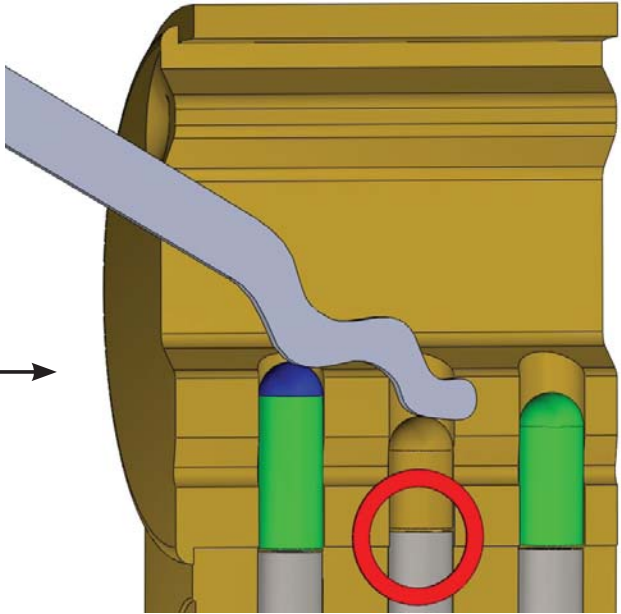

Keep in mind, though, that raking generally gives the ability to try every single combination doable with the rake very quickly.

If, after a few minutes of raking with correct tension, your cylinder is still not open, it probably means that the cylinder contains anti-picking pins or that the height difference between the highest pin and the lowest pin in relation to the curvature of the tool is too great.

Then you will need to use a hook pick to complete the picking, but some pins will have probably been set in place during the raking.

Take good care not to release the tension on your tension tool if you change your pick or raking tool as this will return the pins to their resting position.

3. Illustration of the raking technique

Step n^o 1: a linear action of the tool against the pins

In the example below, two pins are positioned with a linear action.

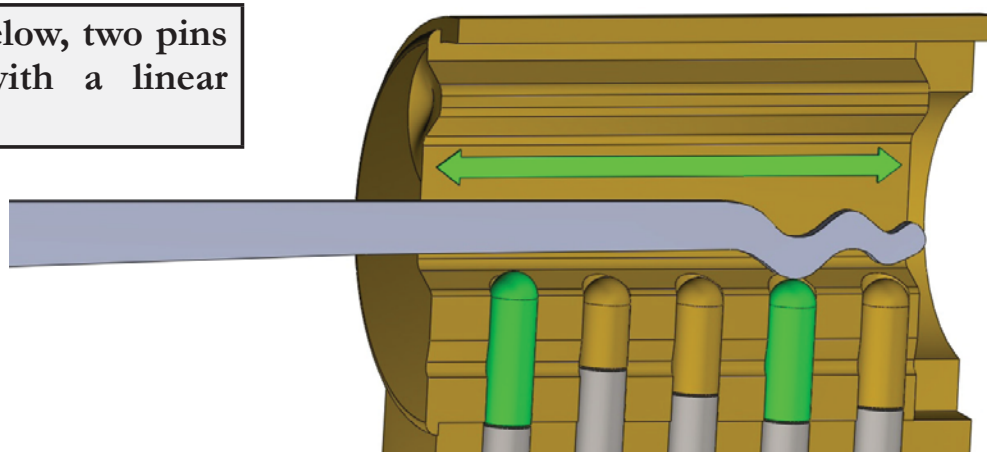

Step n^o 2: lower the angle of the tool to vary the combinations

In this case, the lowered angle does not set a new pin at the shear line.

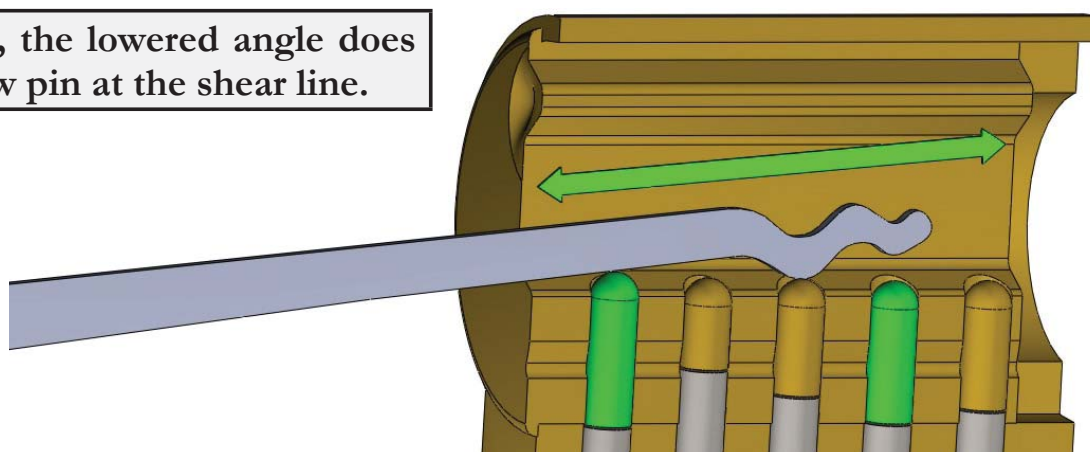

Step n°3: increase the angle of the tool to vary the combinations

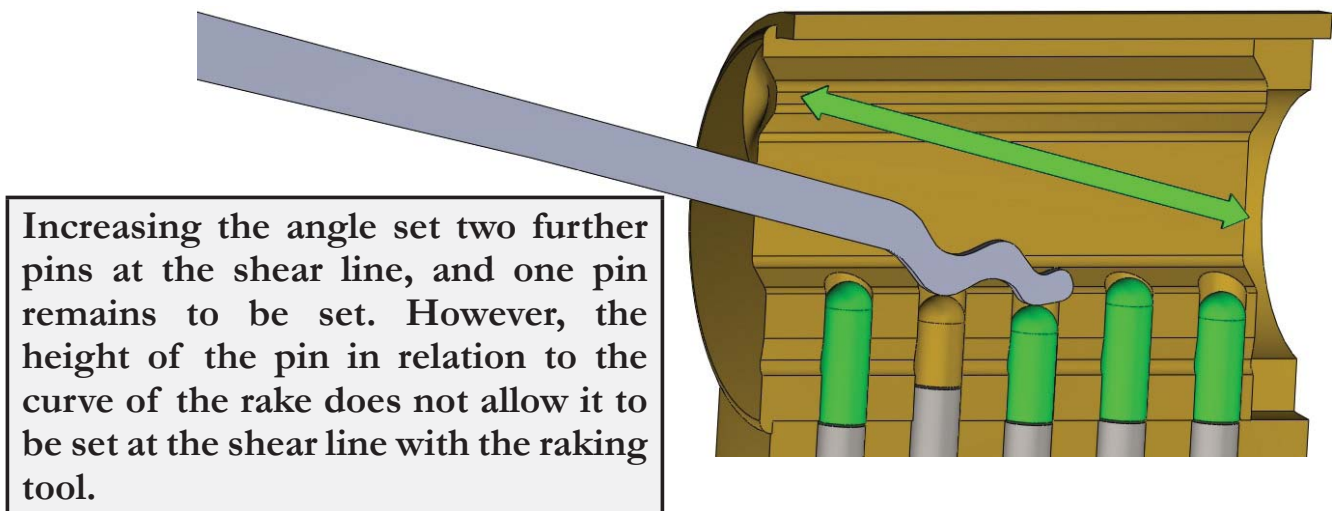

Step n°4: use a hook pick to complete the picking of the cylinder

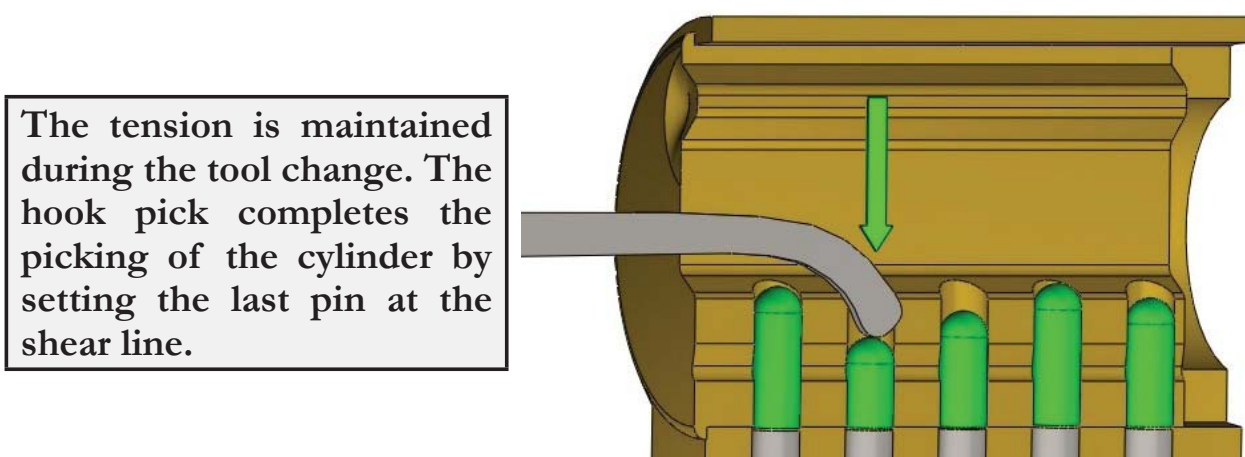

4. Applying the appropriate raking tension

Although we have strongly advised that you start learning to tension a plug from the bottom of the keyway, it is often preferable in the case of raking to tension from almost the middle or the top of the keyway.

In effect, when the lock is being raked, the end of the tension tool will serve as a guide for the rake by sliding against the tension tool to give you a more consistent mechanical action that is more effective on the pins.

If the position of the tension tool needs to be changed, it can be changed to the top or the bottom of the keyway to give a different action.

Using the tension tool as a guide for linear raking

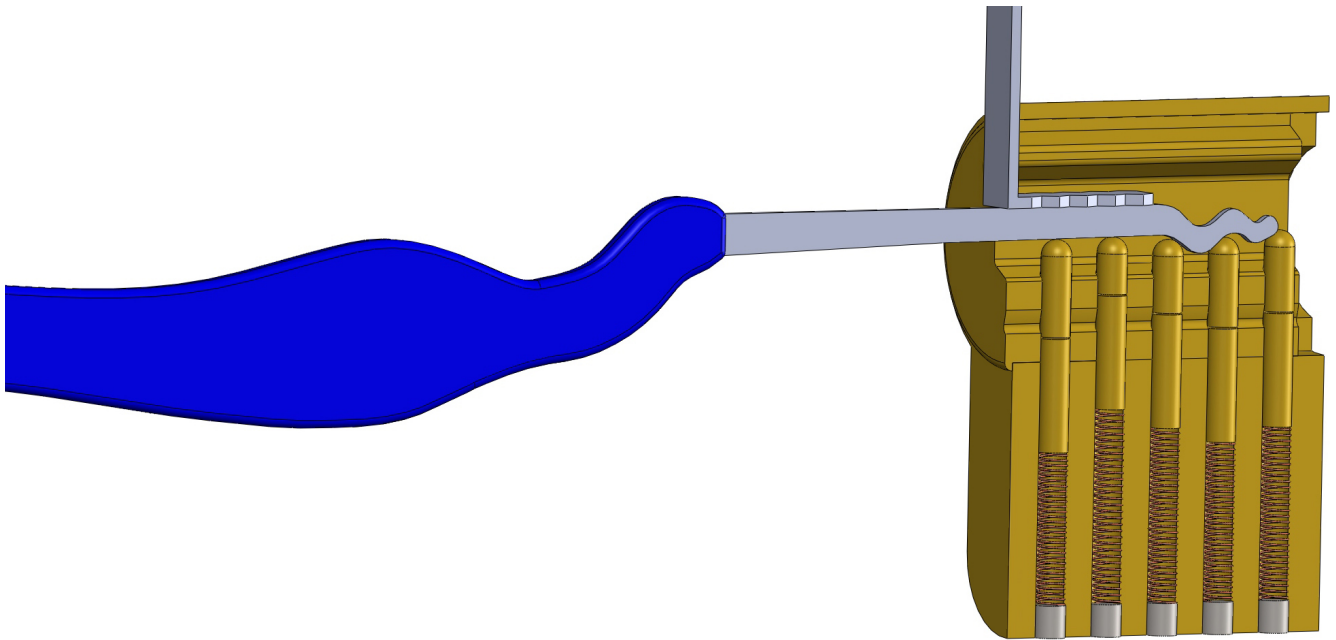

Unlike single pin picking, the pressure on the tension tool needs to be flexible and minimal in order to allow the simultaneous setting of several pins.

If the pins can be heard responding to the spring pressure as the rake passes over them, then the correct tension is being applied. However, this spring 'pinging' can also be heard when there is no tension applied and the pins are not set at the shear line.

It is therefore necessary to hear the sound given by the pins 'pinging' under spring pressure and the sound of the pins that return to rest when the tension is released.

To find the correct tension you need to apply, you can use the following exercise:

1. Pass the rake back and forth over the pins a few times so you can hear the sound made by the pins under spring pressure.
2. Release the tension from your tension tool, and listen if any of the pins return back to their rest position.
3. Repeat this exercise until you are able to get both the sound made by the pins when the rake is passed over them and the sound of the pins made when they return to their rest (unset) position when the tension is released.

When you have these two elements you will have the correct tension that needs to be applied.

5. Usefulness of the raking anti-picking pins

The technique of raking does not necessarily get results with locks that have anti-picking pins such as spools, mushroom pins or serrated pins.

In this situation, it is the hook pick that will allow you to correctly understand these anti-picking pins, and to set them correctly (see the chapter dedicated to anti-picking pins).

In the majority of cases, the pins within a cylinder with anti-picking pins are not all anti-picking pins.

On the other hand, even if all the pins are anti-picking pins, it is nevertheless necessary to start by false setting these anti-picking pins, and then to set them on the shear line correctly. This would be the case except for a key pin that is an anti-picking pin.

As a result, it is useful to use a rake at the beginning of the picking process because it will help to quickly set the regular pins at the shear line and to false set the anti-picking pins.

Preliminary Action of using a rake on an anti-picking pin

The action of a rake positioning pins that does not include anti-picking.

The action of the rake positions the spools in a false set, which allows the plug to turn a few degrees.

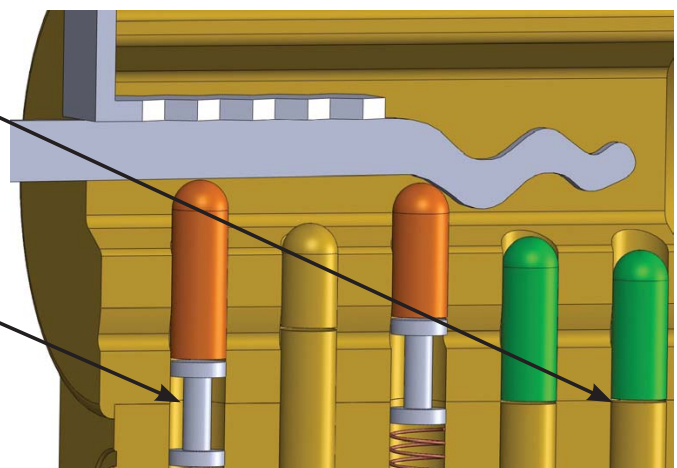

Once the anti-picking pins have been placed at a false set, and the plug rotated by a few degrees, a feeler hook can then be used to set those pins.

It can often happen that some of the pins set at the shear line can become unset because tension needs to be released a little to set the anti-picking pins.

You'll then have the opportunity to use both techniques to set a few of the pins by raking, as well as setting any anti-picking pins with a feeler hook. These two techniques can be alternated until the lock is open.

6. Using single pin picking tools

As explained in the presentation of tools for this technique, there are several forms of picking tools (such as hooks, diamonds, half-moons), and all act in the same way of acting on one pin at a time.

The essential aspect of single pin picking is to apply the correct tension on the plug, while probing the pins individually and gradually setting them at the shear line.

The order that the pins bind takes place through the friction exerted on the pin when rotational tension is put on the plug.

As we have already said, because of the machining defects, when we tension the plug, the plug is then blocked from rotating further by the pins that are trapped between the plug and the shell.

As a result, it is necessary to begin by setting the first binding pin (that which is stopped by friction) because it is likely to stay set at the shear line once it's moved by the feeler pick. This is the most important.

Once this is done, the friction will be binding a new pin, which can be determined by feedback through the pick in order to position the pin correctly. This procedure is then repeated until the cylinder is open.

While the theory of using a picking tool is extremely simple, their practical use is far more complex.

The space available in the keyway depends on the brand and model. Narrow keyways will give you a lot of bad feedback because of the friction of your tool against the keyway itself.

It is not at all an easy technique to learn how to position your tool in the cylinder to place it correctly on top of the pins to set them, as well as maintaining good feedback at the same time.

If possible try to get a cutaway cylinder when you first begin practicing. With that, it's possible to observe how to position your pick on the pins. You will be able to move ahead quickly by being able to associate the action of the tool with the sensations given to you through the tool.

7. Applying the appropriate tension when single pin picking

This subject has already been looked at in depth in the chapter on tensioning; please refer to that for a complete explanation.

However, keep in mind that the best training for single pin picking is, according to us, carried out by tensioning from the bottom of the keyway while being sure the tension tool is not obstructing the movement of the first pin.

The necessary tension is preferably applied with a short rigid tension tool in order to rotate the plug a few degrees from its position of rest. This is necessary in order to create the necessary friction on the pins that sit between the plug and the shell.

8. The transition to turn a 180° picked cylinder :

Now you have mastered the techniques of both raking and single pin picking, there is nothing that will prevent you from opening your first cylinders.

Nevertheless, a problem may arise when you have picked and you try to turn the plug a complete turn in order to open the lock. In this case you may find that the plug is blocked once you've turned the plug 180 degrees.

This is not a malfunction of the cylinder and is nothing to worry about. There is no point in trying to pick the cylinder again because it is already picked despite only rotating 180 degrees.

In reality, when the plug has rotated 180 degrees the driver pins drop into the bottom groove of the plug, and that prevents any further rotation.

Of course, this situation is specific to picking a lock because when a key is inserted it fully fills the plug groove and prevents the driver pins dropping in to the groove.

A picked cylinder, the plug locked in rotation at 180°

The driver pins emerge during the half-turn and prevent the plug from rotating further.

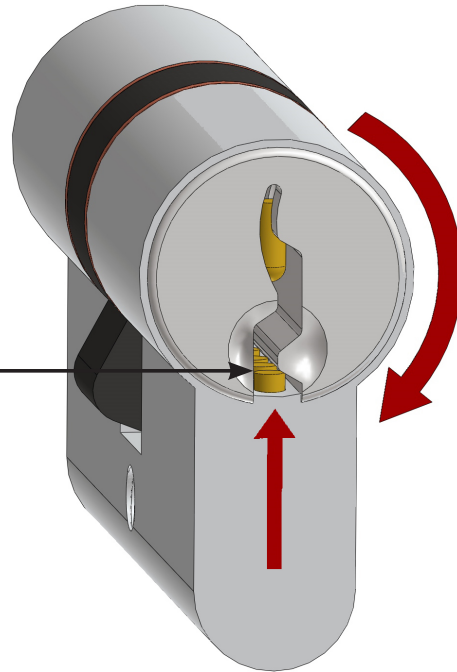

To overcome this problem, you simply need to push back the driver pins using the length of a pick and continuing the rotation with a tension tool to finish the opening in the normal way.

Unblocking a cylinder trapped at 180 degrees

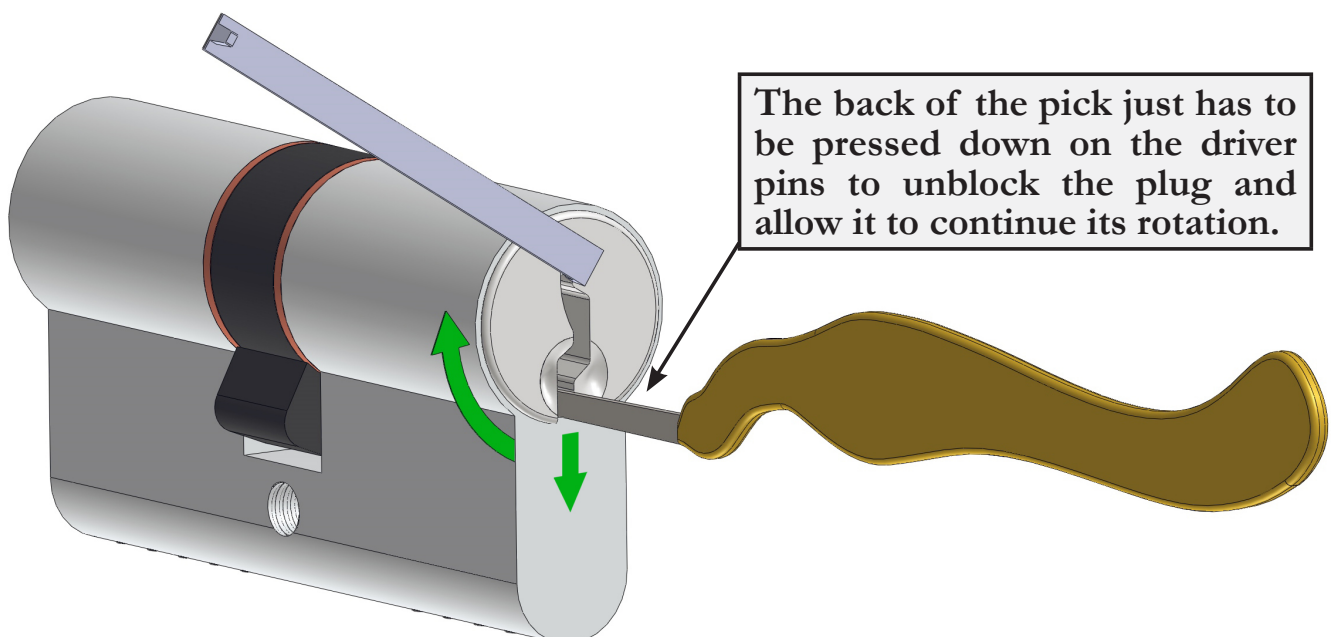

The back of the pick just has to be pressed down on the driver pins to unblock the plug and allow it to continue its rotation.

Conclusion

We hope we have been able to provide you with an extensive overview of how a lock operates in this document, and how it can be opened non-destructively through picking the vast majority of common pin tumbler lock systems.

Of course, the professional practice of the lock manipulation requires the mastery of other techniques such as the decoding, impressioning, bumpkeys, and the use of umbrella picks etc. ..

In terms of the wide range of tasks a professional locksmith may meet, a wide range of techniques is essential to find a satisfactory solution to whatever challenge he encounters.

The true professional is one who will discern the disadvantages of any particular technique and give his client a graduated response, starting with using fine techniques, and finish if necessary by pulling or drilling the lock.

Even if it can be argued that the use of methods of fine lock manipulation does not always allow the resale of a cylinder after opening it, you will find that your customers will prove quite inclined to follow your recommendations when you've opened their door in a few minutes without any damage.

On the other hand, a satisfied customer, or even one impressed by your work, will speak of you in good terms to his friends more than he may have done if you would have opened the lock destructively. As a result, you extend the circle of your customer loyalty.

If you have any question or suggestion : frenchkey@frenchkey.fr

Alexandre Triffault

www.intrusion.eu